

AP2718AT is an omnidirectional, stable, low power, top port, analog MEMS microphone. The AP2718AT consists of a MEMS acoustic transducer and a low noise amplifier, which is suitable for cellphones, Bluetooth earphones, headsets, and other portable electronic devices.

Features:

- Flat frequency response
- Low current consumption
- Omnidirectional
- Good uniformity
- Standard SMD Reflow

Typical applications:

- Cellphones
- Bluetooth earphones
- Headsets
- Laptops
- Digital cameras

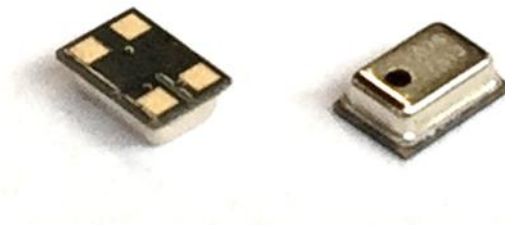

1. ABSOLUTE MAXIMUM RATINGS

Parameter	Maximum Rating	Units
V _{DD} to GND	-0.3 to +5.5	V
ESD Tolerance (HBM)	±2.0	kV
ESD Tolerance (CDM)	±200	V
Storage Temperature	-40 to +105	°C

Stresses exceeding these “Absolute Maximum Ratings” may cause permanent damage to the device. These are stress ratings only. Functional operation at these or any other conditions beyond those indicated under “Acoustic & Electrical Specifications” is not implied. Exposure beyond those indicated under “Acoustic & Electrical Specifications” for extended periods may affect device reliability.

2. ACOUSTIC & ELECTRICAL SPECIFICATIONS

Test condition: 25±2°C, 45±20% R.H., unless otherwise indicated.

Parameter	Symbol	Min	Typ	Max	Units	Conditions ¹
Directivity	-	Omnidirectional				
Sensitivity	S	-43	-42	-41	dBV/Pa	94 dB SPL @ 1 kHz
Signal to Noise Ratio	SNR		57		dB(A)	94 dB SPL @ 1 kHz, A-weighted
Total Harmonic Distortion	THD		0.1		%	94 dB SPL @ 1 kHz
Acoustic Overload Point	AOP		125		dB SPL	10% THD @ 1 kHz
Supply Voltage	V _{DD}	1.6		3.6	V	
Supply Current	I _{DD}		95	110	μA	
Power Supply Rejection Ratio	PSRR		66		dB	200 mVpp sinewave @ 1 kHz, V _{DD} = 1.8 V
Power Supply Rejection	PSR		-92		dB	100 mVpp square wave @ 217 Hz, V _{DD} = 1.8V, A-weighted
Output DC Impedance	-		220	300	Ω	

3. FREQUENCY RESPONSE CURVE

Typical Free Field Response Normalized to 1 kHz @ 94 dB SPL

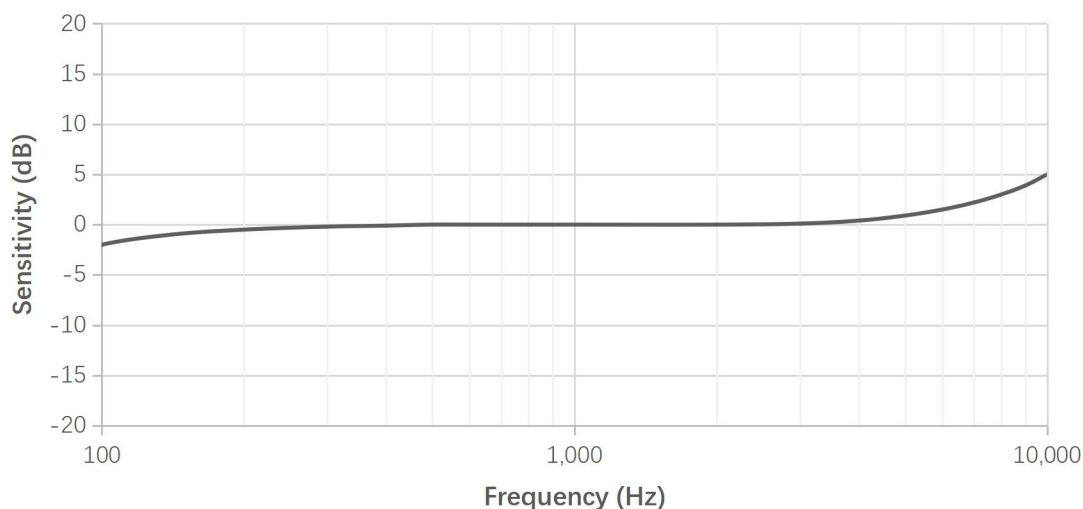

4. APPLICATION CIRCUIT

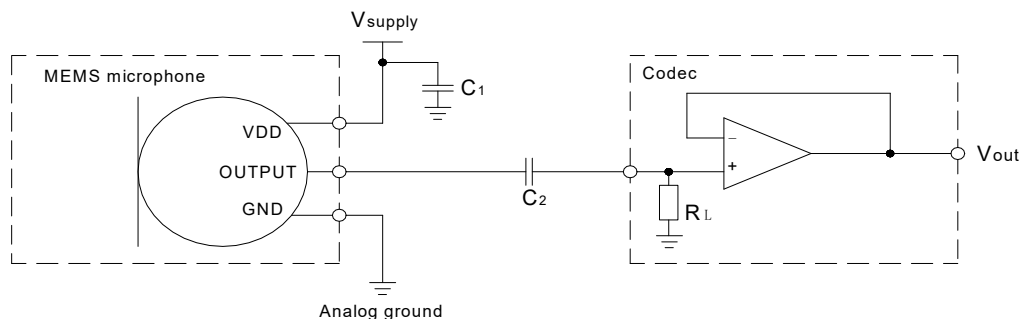

Power supply decoupling:

A 0.1 μ F ceramic type decoupling capacitor C1 is strongly recommended for every microphone and it should be placed as close to the VDD pad to reduce the noise on power supply;

The trace connected to each pad of capacitor should be as short as possible, and should stay on one layer of PCB without via. For the best performance, recommend to place the capacitor equidistance from power and ground pins of microphone, or slightly closer to the power pin if space not allowed. System ground should connect to far side of the capacitor

5. MECHANICAL SPECIFICATIONS

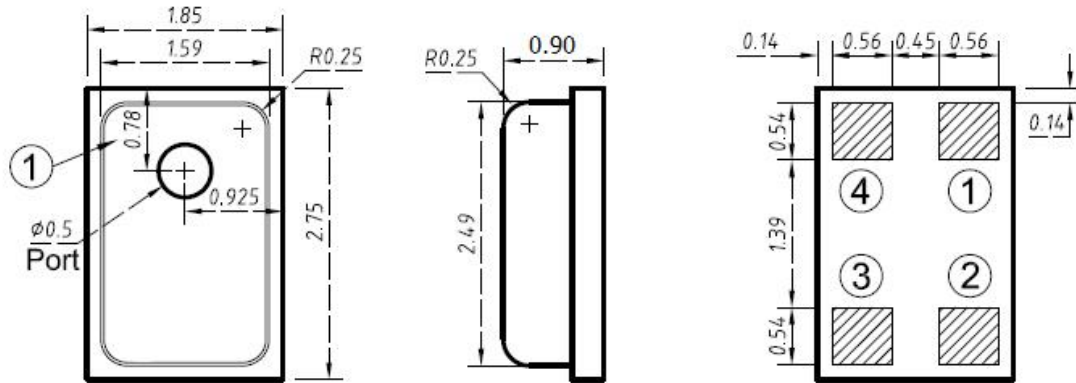

Item	Dimension	Tolerance
Length (L)	2.75	±0.10
Width (W)	1.85	±0.10
Height (H)	0.90	±0.10
Acoustic Port (AP)	∅0.5	±0.05

Pin #	Description	Pin Name
1	Output Signal	OUT
2	Ground	GND
3	Ground	GND
4	Power Supply	V _{DD}

Dimensions are in millimeters unless otherwise specified.

Tolerance is ±0.15mm unless otherwise specified

6. EXAMPLE OF LAND PATTERN

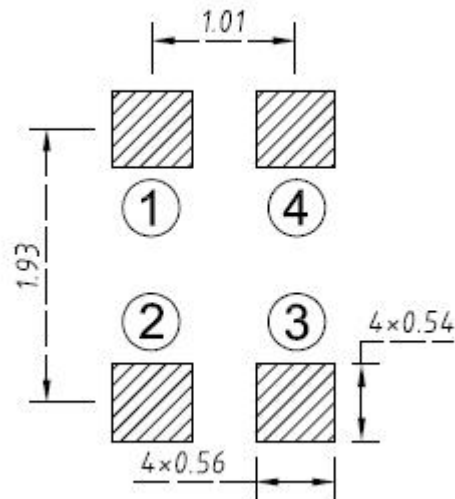

7. EXAMPLE SOLDER STENCIL PATTERN

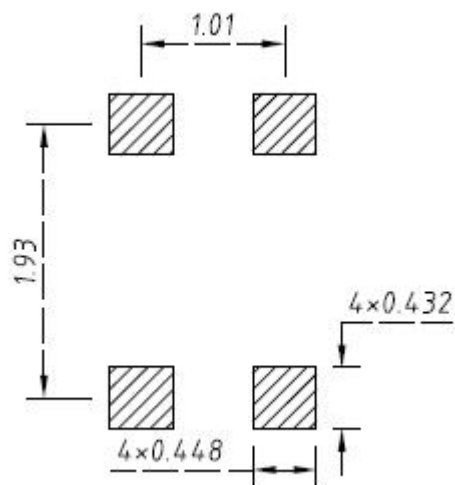

Note: Dimensions are in millimeters unless otherwise specified.

8. PACKING & MARKING DETAIL

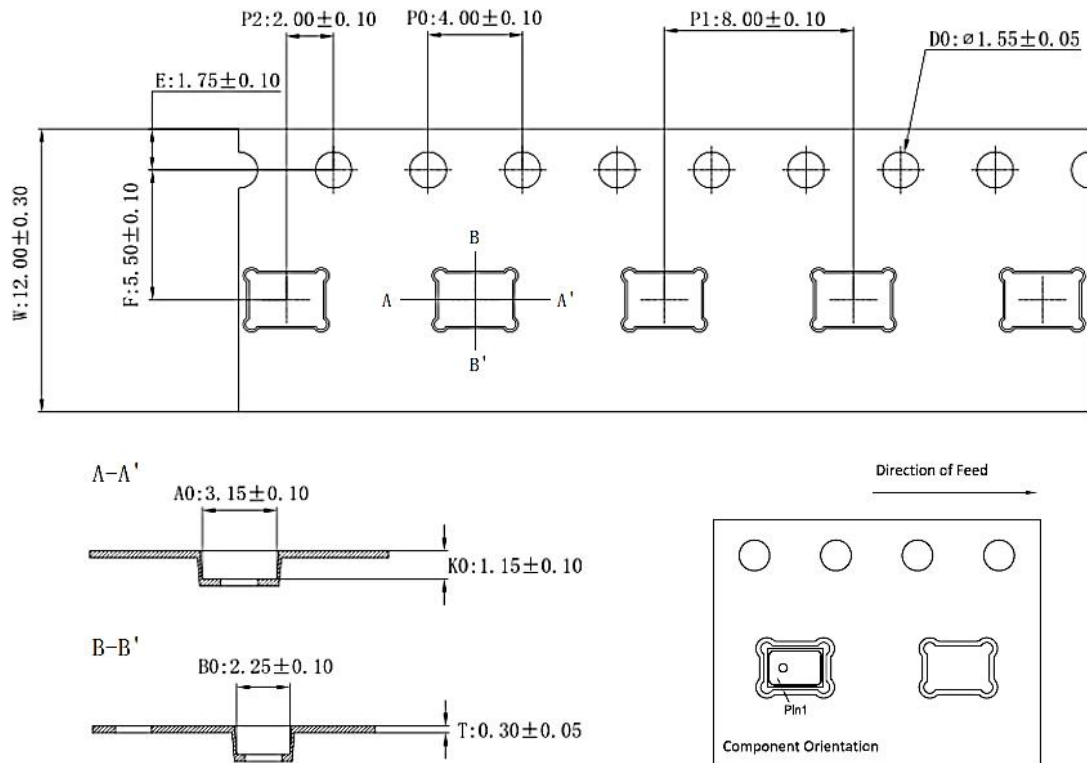

Note:

- 1) Dimensions are in mm;
- 2) Do not push the vacuum suction nozzle alignment the port hole;
- 3) Tape & Reel Per EIA-481 standard;
- 4) Label applied to external package and direct to reel;
- 5) Static voltage <100V

Model Number	Reel Diameter	Quantity per Reel
AP2718AT	13 inches	5000

9. RECOMMENDED REFLOW PROFILE

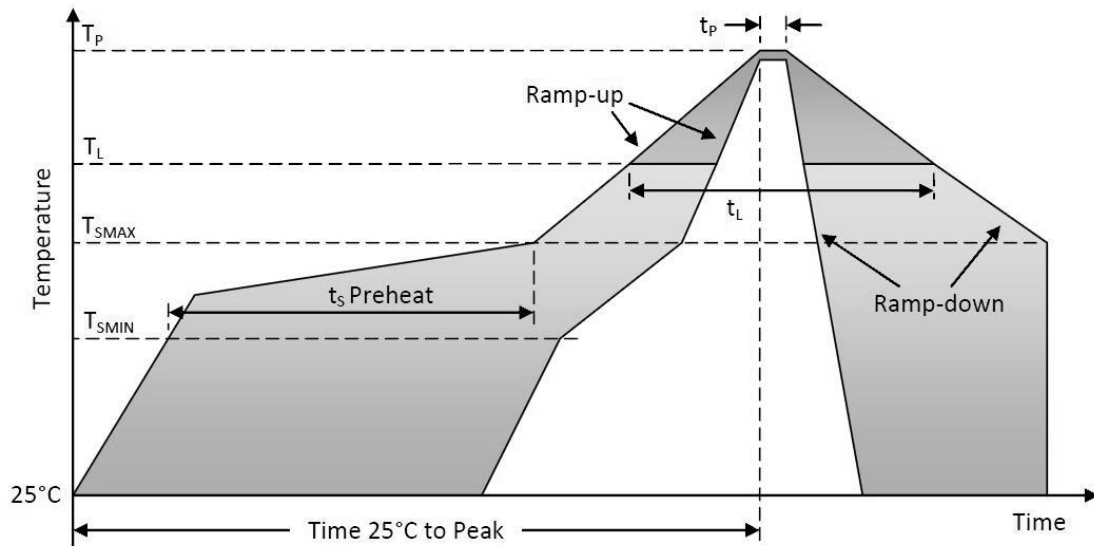

Profile Feature	Pb-Free
Average Ramp-up rate (T_{SMAX} to T_P)	3°C/second max.
Preheat	
- Temperature Min (T_{SMIN})	150°C
- Temperature Max (T_{SMAX})	200°C
- Time (T_{SMIN} to T_{SMAX}) (t_s)	60-180seconds
Time maintained above:	
- Temperature (T_L)	217°C
- Time (t_L)	60-150 seconds
Peak Temperature (T_P)	260°C
Time within 5°C of actual Peak Temperature (t_p)	20-40 seconds
Ramp-down rate (T_P to T_{SMAX})	6°C/second max
Time 25°C to Peak Temperature	8 minutes max

10. ADDITIONAL NOTES

(A) MSL (moisture sensitivity level) Class 2.

(B) Maximum of 3 reflow cycles is recommended.

(C) In order to minimize device damage:

- Do not board wash or clean after the reflow process.
- Do not brush board with or without solvents after the reflow process.
- Do not directly expose to ultrasonic processing, welding, or cleaning.
- Do not insert any object in port hole of device at any time.
- Do not apply over 30 psi of air pressure into the port hole.
- Do not pull a vacuum over port hole of the microphone.
- Do not apply a vacuum when repacking into sealed bags at a rate faster than 0.5 atm/sec.

11. RELIABILITY SPECIFICATIONS

Test	Condition
Thermal Shock	100 cycles air-to-air thermal shock from -40°C to +125°C with 15 minute soaks. (IEC 68-2-14)
High Temperature Storage	1,000 hours at +105°C environment (IEC 68-2-2 Test Ba)
Low Temperature Storage	1,000 hours at -40°C environment (IEC 68-2-1 Test Aa)
Temperature / Humidity	1,000 hours at +85°C/85% R.H. . (JESD22-A101A-B)
Vibration	4 cycles of 20 to 2,000 Hz sinusoidal sweep with 20 G peak acceleration lasting 12 minutes in X, Y, and Z directions. (Mil-Std-883E, Method 2007.2 A)
ESD-HBM	3 discharges of ±2 kV direct contact to I/O pins. (MIL 883E, Method 3015.7)
ESD-LID/GND	3 discharges of ±8 kV direct contact to lid while unit is grounded. (IEC 61000-4-2)
ESD-MM	3 discharges of ±200 V direct contact to I/O pins. (ESD STM5.2)
Reflow	5 reflow cycles with peak temperature of +260°C
Mechanical Shock	3 pulses of 3,000 G in the X, Y, and Z direction (IEC 68-2-27, Test Ea)
Drop Test	To be no interference in operation after dropped in 150g block from a height of 1.5m onto a steel base 18 times in the direction of ±X, ±Y, ±Z

Notes: After reliability tests are performed, the sensitivity of the microphones shall not deviate more than 3 dB from its initial value.