

JYH HSU (JEC) ELECTRONICS LTD.,

Approved/Recognized Type

Related Standard		Certificate NO	APPROVED Monogram
CQC (China)	IEC 60384-14	CQC13001103540	
KC (Korea)	K60384	SU03044-9001	
UL(usa) CSA(Canada)	IEC UL 60384	E356696	
ENEC (EU)	EN 60384-14	ENEC-00982-A1	
VDE (Germany)	EN 60384-14	40038642	
IEC CB	IEC 60384-14	US-33637-UL	

Specifications

Operating Temp.Range	-40°C to +85°C		
Use temperature range	-40°C to +125°C		
Applicable Standards	UL, CSA, CQC, ENEC, VDE	X1	Y1
		400VAC	400VAC
Dielectric Withstanding Voltage	Rtd Voltage		Test Voltage
	400VAC		4000 VAC for 1 min.
Dissipation Factor (D.F)	Y5P, Y5U	TANδ(DF) ≤ 2.5%, measured at 1KHz±10%, 1.0 – 5.0 Vrms, 25°C	
	Y5V	TANδ(DF) ≤ 5.0%, measured at 1KHz±10%, 1.0 – 5.0 Vrms, 25°C	
Capacitance(C)	Range	10 pF to 10000 pF. measured at 1KHz±10%, 1.0 – 5.0 Vrms, 25°C	
	Tolerance	±10%	Y5P
		±10%	Y5U
		±20%	
±20%		Y5V	
Insulation Resistance(IR)	10000 MΩ , 1 min , 100 VDC		
Temperature Characteristics	Type Code	Temp. Coeff.	Temp. Range
	Y5P	±10%	-40°C to +85°C, -40°C to +125°C
	Y5V	+30%~-89%	-40°C to +85°C, -40°C to +125°C
	Y5U	+22%~-65%	-40°C to +85°C, -40°C to +125°C

Part Number Configuration:

JD 102 M 2G Y5V S T 10 L

(1) (2) (3) (4) (5) (6)(编带) (7) (8)

- (1) AC capacitors, safety
- (2) Rated capacitance
- (3) Tolerance on rated capacitance
- (4) Rated Voltage
- (5) Type code: (B)Y5P, (F)Y5V, (E)Y5U
- (6) Lead shape: S(直角), I(内弯), O(外弯), X(前后弯)
- (7) Pin pitch : 7.5or9.5or10.0
- (8) Lead length: 3-25mm

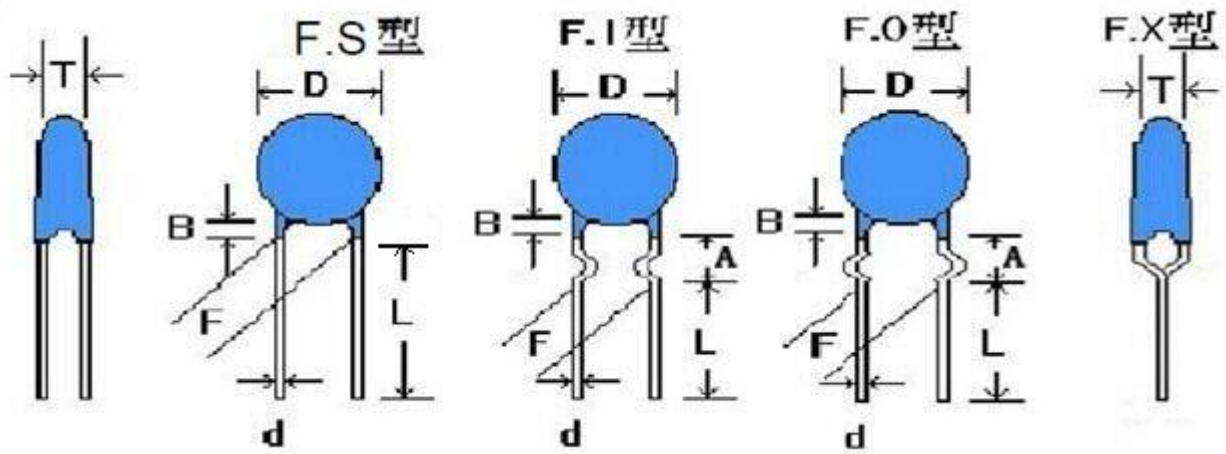

Dimensions and Tolerance

B=3.0mm max for AA

L=3-27mm

编带详细参数看 P11.

承认规格详细参数 (Approved Spec. Data)

品名规格	D(MAX)	F±0.8	L(MIN)mm	T±0.5mm	d±0.05mm	B	DF	A	备注

Marking:

- a. Trademark or Company name 
- b. Product Type JD Series
- c. Nominal Capacitance & Tolerance 471=470pF, K= ±10%, M= ±20%
- d. Safety Class such as Y1
- e. Recognized Type
- f. Rated Voltage

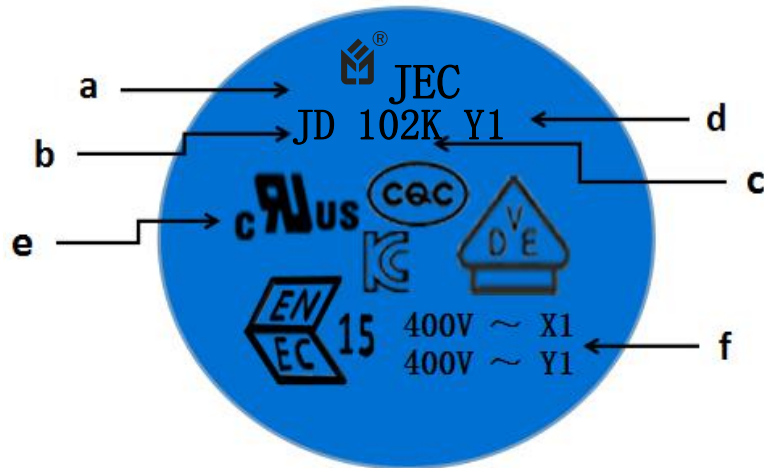

1. Packing Quantity:

Packing	Safety	High Voltage	<i>Ceramic</i>
	Capacitor	Capacitor (Y1, Y2)	<i>Capacitor DC</i>
Bulk	1000pcs	1000pcs	<i>1000pcs</i>
Tape Ammo	2000pcs	1500pcs	<i>2000pcs</i>

ROHS Compliance , SVHC

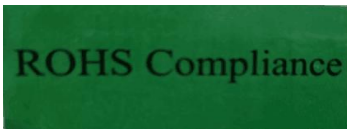

2. Packing information

2.1 the number of plastic bags in each bag is 1000 PCS. Internal label and ROHS qualification label.

2.2 the quantity of each small box is 10k-30k. 1K is a bag. It depends on the product volume.

2.3 each large box can hold two small boxes.

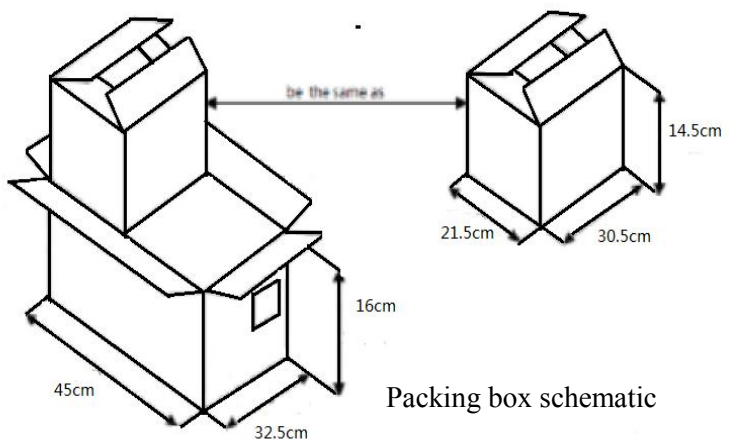

Packing box schematic

料號編碼規定如下:

成品之編碼原則上以十五碼完成, 亦以阿拉伯數字與英文字母混合編成, 第二碼至第十一碼與瓷片相同。第一碼以 J 代表自製 (取 JEC 商標第一字)

The coding of the finished product is in principle 15 codes, which are mixed with Arabic numerals and English letters. Sizes 2 to 11 are the same as the tiles. The first code is represented by J (take the first word of JEC trademark).

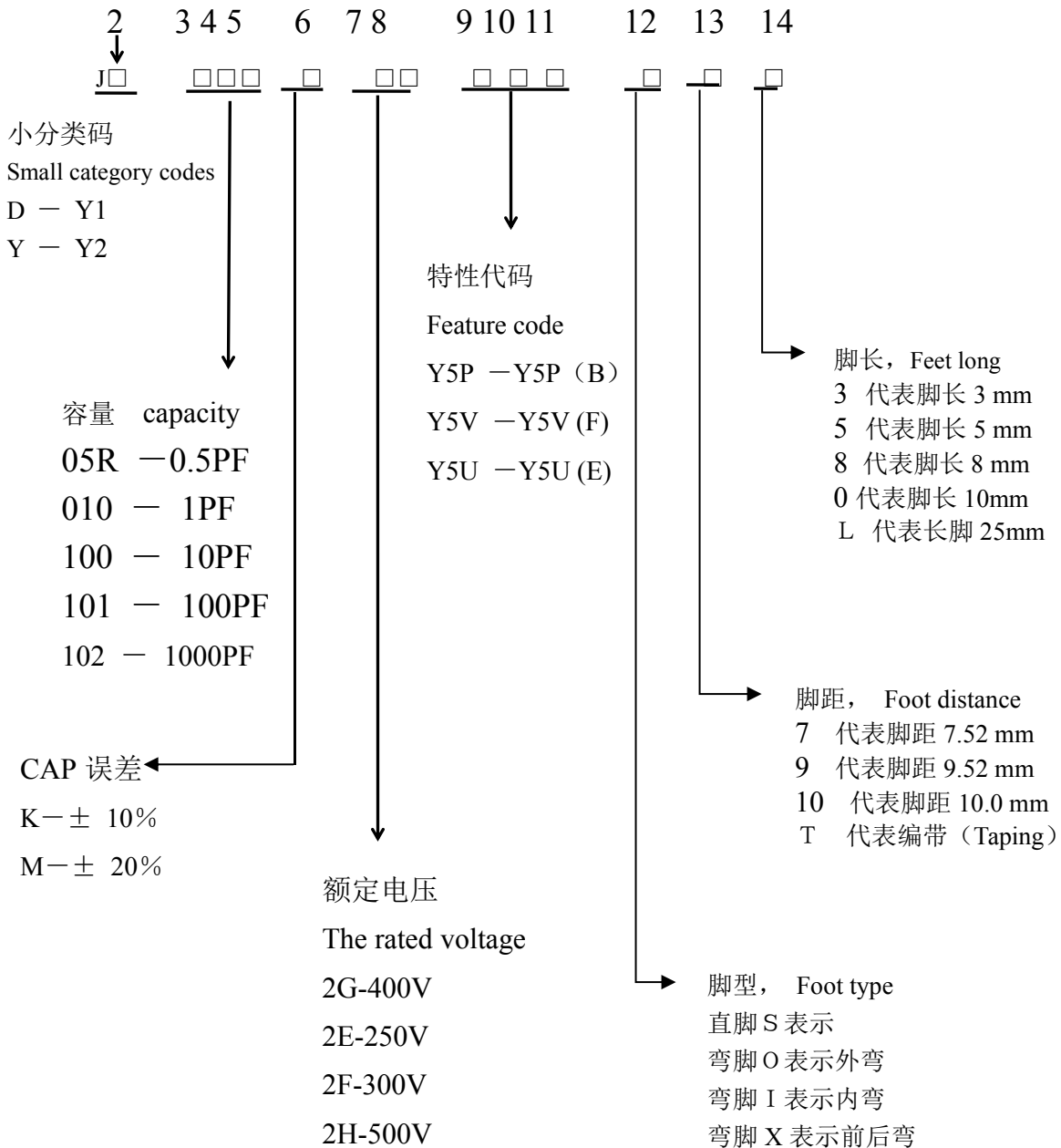

Capacitance and Dimensions:

Part Number	T.C.	CAP.	TOL.	Dimension(mm)				
				D max	F±0.8MM		T max	Φ d(±0.05)
JD10K2GY5P To JD82K2GY5P	±10% (Y5P)	10pF To 82PF	K ±10%	6.8	9.5	10.0	6	0.55
JD101K2GY5P		100PF		6.8				
JD151K2GY5P		150PF		6.8				
JD221K2GY5P		220PF		6.8				
JD331K2GY5P		330PF		7.2				
JD471K2GY5P		470PF		8.8				
JD561K2GY5P		560PF		8.8				
JD681K2GY5P		680PF		9.8				
JD102K2GY5P		1000PF		10.2				
JD471K2GY5U		+22 ~-65% (Y5U)		470PF				
JD561K2GY5U	560PF		7.8					
JD681K2GY5U	680PF		7.2					
JD102M2GY5U	1000PF		7.8					
JD152M2GY5U	1500PF		9.3					
JD222M2GY5U	2200PF		10.7					
JD332M2GY5U	3300PF		13.0					
JD392M2GY5U	3900PF		15.0					
JD472M2GY5U	4700PF	15.0						
JD102M2GY5V	+30 ~-89% (Y5V)	1000PF	M±20%	6.8	9.5	10.0	6	0.55
JD152M2GY5V		1500PF		7.8				
JD222M2GY5V		2200PF		8.5				
JD332M2GY5V		3300PF		10.2				
JD392M2GY5V		3900PF		11.4				
JD472M2GY5V		4700PF		11.4/12.0				
JD103M2GY5V		10000PF		16.5				

注：本规格仅作参考，在没有告知的情况下，有可能变更或改进，如有需求请咨询我司。

EIA TEMPERATURE CHARACTERISTIC CHART																										
First Digit is low Temperature	Second Digit is High Temperature	Last Digit is Capacitance Change Over Temperature Range From +25 °C Reading																								
X: -55°C Y: -25°C Z: +10°C	4: +65°C 5: +85°C 6: +105°C 7: +125°C 8: +150°C	<table border="0"> <tr><td>A</td><td>± 1.0 %</td></tr> <tr><td>B</td><td>± 1.5 %</td></tr> <tr><td>C</td><td>± 2.2 %</td></tr> <tr><td>D</td><td>± 3.3 %</td></tr> <tr><td>E</td><td>± 4.7 %</td></tr> <tr><td>F</td><td>± 7.5 %</td></tr> <tr><td>P</td><td>± 10 %</td></tr> <tr><td>R</td><td>± 15 %</td></tr> <tr><td>S</td><td>± 22 %</td></tr> <tr><td>T</td><td>+ 22 % - 33 %</td></tr> <tr><td>U</td><td>+ 22 % - 56 %</td></tr> <tr><td>V</td><td>+ 22 % - 82 %</td></tr> </table>	A	± 1.0 %	B	± 1.5 %	C	± 2.2 %	D	± 3.3 %	E	± 4.7 %	F	± 7.5 %	P	± 10 %	R	± 15 %	S	± 22 %	T	+ 22 % - 33 %	U	+ 22 % - 56 %	V	+ 22 % - 82 %
A	± 1.0 %																									
B	± 1.5 %																									
C	± 2.2 %																									
D	± 3.3 %																									
E	± 4.7 %																									
F	± 7.5 %																									
P	± 10 %																									
R	± 15 %																									
S	± 22 %																									
T	+ 22 % - 33 %																									
U	+ 22 % - 56 %																									
V	+ 22 % - 82 %																									

Capacitance Temperature Characteristics

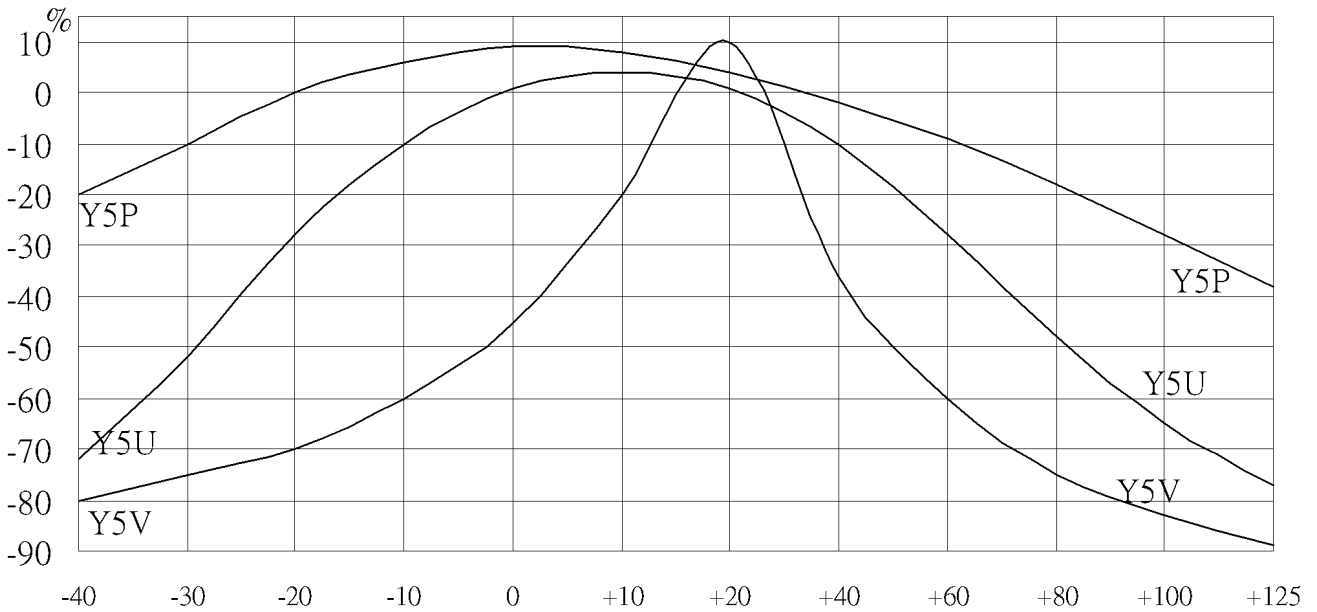

JYH HSU (JEC) ELECTRONICS LTD.,

Performance & Tests, draw up by IEC 60384-14:2005 and GB/T 6346

"Note: (1) Is was defined according with IEC 60384-14:2005, when for qualification approval and periodic tests, the withstanding test must last to 1 minute, and it belong to destroyed test domain, therefore, after the test, capacitors should be scrap. Withstand voltage test should rise slowly at 150V/s, and test time is counted from when the voltage reaches to experiment requirement." (2)

The test time is more than 1 second at production period, and the rated test voltage is applied.

Capacitors may cause to damage when withstand voltage test repeated."

NO.	Item	Characteristic	Test Method	
1	Appearance and Dimensions	Please refer to figures and tables on page 2, 3 and 4.	1~1 1~2	"Production line visual inspection must be done in full and remove the defective products." "Dimensions measurement by micrometer and Caliper
2	Marks	Must be clean and clear.	2~1	Label need to be able endure wiping with Isopropanol
3	Withstand voltage test (I)	Between terminal	3~1	Rated voltage: 300VAC for Y2, test voltage 2000 VAC or 2600 VAC, time 60s, frequency: 50Hz/60Hz. Rated voltage: 400VAC for Y1, test voltage 4000 VAC, Approval and period test: 60s, Lot inspection 100% and time 2s, discharge current must ≤ 50 mA."
		Between terminal and coating.	3~2	Use metal foil test method: use metal foil wrap around the capacitor body, each end extending at least 5mm, and keep 1mm/1kV distance minimum, between metal foil and terminals. for Y2, test voltage 2300VAC; for Y1, test voltage 4000VAC, test time 60s.
4	Withstand voltage test(III) (For safety symbol A2)	(1)Gauze shall not ignite. (2)Capacitors shall not in burned.	4~1	According to IEC 60384-14 and GB/T6346 requirements.
5	Withstand voltage test (IV)(For safety symbol B2)	(3)Elements and coating must not scattered. (4)Terminals can not be moved away from the mounting position than 3mm.	5~1	According to IEC 60384-14 and GB/T6346 requirements.
6	I	Between terminals	6~1	Measured voltage is $500 \pm 15V$ within 1 minute, and IR keeps within the specified value.
	R	Between terminals and coating.		
7	Capacitance	Within specified tolerance	7~1	The Capacitance shall be measured at 25°C, with $1 \pm 0.1kHz$ and $5V_{rms}$ max
8	Dissipation Factor(D.F)	B(Y5P) $\tan \leq 2.5\%$ E(Y5U) $\tan \leq 2.5\%$ F(Y5V) $\tan \leq 5.0\%$	8~1	"The Dissipation Factor shall be measured at 25°C with $1 \pm 0.1kHz$ and $5V_{rms}$ max

JYH HSU (JEC) ELECTRONICS LTD.,

NO	Item	Characteristic		Test Method			
9	Temperature Characteristic	Temperature Coefficient (T.C. category applicable):		9~1	Temperature Coefficient (T.C. category applicable):		
		TYPE Temp.Range	SL	YN	9~2	$\text{PPM}/^{\circ}\text{C} = (\text{Ct2} - \text{Ct1}) / \text{Ct1} * (\text{t2} - \text{t1})$	
		20~85°C	+ 350~ -1000pp m/C	- 800~ -5800 ppm/C		Ct2: the capacitance of t2 Ct1: the capacitance of t1 t2: 85°C±3°C t1: 20°C±2°C	
		Temperature characteristics: (High Dielectric applicable) Capacitance change rate within the range: Type B Within ±10% Type E Within +22% -56% Type F Within +30% -80%		9~3	Temperature phase 1) 20±2°C → 2) -25±2°C → 3) 20±2°C → 4) 85±2°C → 5) 20±2°C Capacitance change: (High Dielectric Category applicable) $C.C(\%) = (\text{Ctx} - \text{Ct20}) / \text{Ct20} * 100$ Ctx : Except Temp. phase 1、3、5, The capacitance of any temperature between phase 2 to phase 4. Ct20: The capacitance of phase 3 temp.		
10	Robustness of terminations	Tensile	Lead wires not be snapped	10~1	Diameter(mm)	Load(kgs)	Time(sec)
			Capacitors not be damaged		0.5Φ	0.5	10
					0.6Φ~0.8Φ	1	10
		10~2		Fix the capacitor's body and apply a tensile weight gradually to each lead wire in the radial direction			
		Bending	Lead wires not be fractured Capacitors not be damaged	10~3	Diameter(mm)	Load(kgs)	Bending angle is 90 more than twice.
					0.5Φ	0.25	
0.6Φ~0.8Φ	0.5						
11	Vibration resistance	Appearance	No significant abnormal	11~1	Vibration frequency from 10Hz to 55Hz and back to 10Hz, amplitude 1.5mm, period time within 1 minute.		
		Cap. Change	Within specification				
		Q or DF	within initial specification				
12	Soldering Heat Resistance	Appearance	No significant abnormal	12~1	Solder temperature 350±10°C		
		Dielectric Strength I	compliance with the characteristic as No.3	12~2	Immersion time 3.0± 0.5sec		
		Capacitance change rate	B: within ±10% E: within ±15% F: within ±20%	12~3	Placed at room condition for 4~24 hours, and then to measure.		

JYH HSU (JEC) ELECTRONICS LTD.,

No	Item	Characteristic		Test Method		
13	Solder ability	The round surface of lead wires, there must be 3/4 area welding with the solder.		13~1 13~2	Solder temperature 275±10℃ Immersion time 2.0± 0.5sec	
14	Humidity (Under Steady State)	Appearance	No significant abnormal	14~1	Temperature: 40±2℃	
		Dielectric Strength I	Must meet the requirements of No.3	14~2	Humidity: 90~95%RH	
		I R	Between terminals	More than the 1/2 value of No.6 requirements.	14~3	Time: 500±12 Hrs
			Between terminal & coating		14~4	Remove & placed at room condition for 1~2 hours, and then to measure.
		Capacitance change rate	Type B within ±15% Type E within ±20% Type F within ±30%			
		Dissipation Factor (D.F)	Type B & E, under 5%. Type F, under 7.5%			
15	Damp heat loading	Appearance	No significant abnormal	15~1	Temperature: 40±2℃	
		Dielectric Strength I	Must meet the requirements of No.3	15~2	Humidity: 90~95%RH	
		I R	Between terminals	More than the 1/2 value of No.6 requirements.	15~3	Time: 500±12 Hrs
			Between terminal & coating		15~4	Voltage: AC 180Vrms
		Capacitance change rate	Type B within ±15% Type E within ±20% Type F within ±30%	15~5	Current: Less than 50mA	
		Dissipation Factor (D.F)	Type B & E, under 5% Type F, under 7.5%.	15~6	Remove & placed at room condition for 1~2 hours, and then to measure.	

JYH HSU (JEC) ELECTRONICS LTD.,

No	Item	Characteristic		Test Method		
16	Endurance	Appearance		16~1	Temperature: 85±3℃; 125±5℃ Time: 1000±12 Hrs Voltage: rated voltage of 1.7UR Current: less than 50mA Remove & placed at room condition for 1~2 hours, and then to measure.	
		Dielectric Strength I		16~2		
		I R	Between terminals	More than the 1/2 value of No.6 requirements.		16~3
			Between terminal&coating			16~4
		Capacitance change rate		16~5		Type B within ±15% Type E within ±20% Type F within ±30%
		Dissipation Factor (D.F)				Type B & E, under 5% Type F, under 7.5%
17	Flame Test		Applicable safety symbols A2, B2.		The capacitor should be subjected to applied flame for 15 sec, and then removed for 15 sec, until 3 cycles are completed. And then continued to flame a minute and never to explode.	
18	Solvent Resistance (Body)		After the test must meet the standards of its electrical properties		The capacitor should be immersed into a isopropyl alcohol for 5±0.5 minutes, then removed and placed for 48 hrs. at room condition before post measurements.	
19	Solvent Resistance (Mark)		Marks should be legible		Use cotton yarn dips isopropyl alcohol, by force 5±0.5 N/1 cm ² , 1 second round trip twice to wipe mark on the body, and run 5 cycles.	

TAPING SPECIFICATIONS

Taping (Radial)--Lead Spacing F=7.5±0.8 or 10.0±0.8

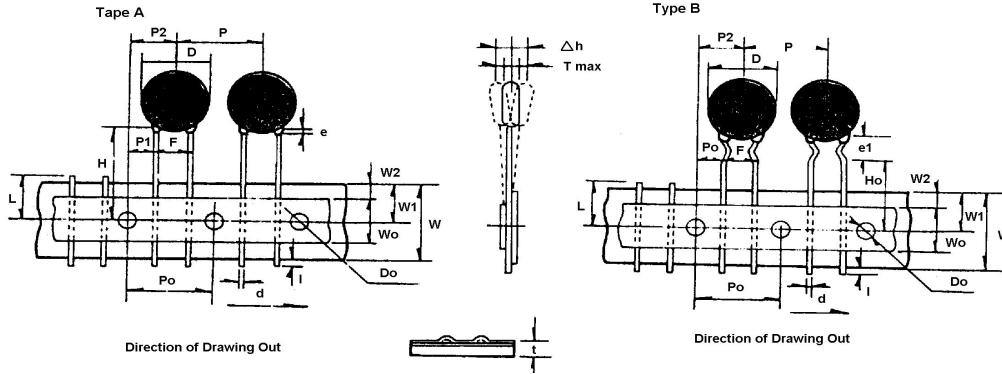

Item	Code	Dimensions (mm)	Item	Code	Dimensions (mm)
Taping Pitch	P	12.7±1.0	Lead Protrusion	l	+0.5~1.0
Guide Pitch	Po	12.7±1.0	Diameter of Feed Hole	Do	4.0±0.3
Lead Spacing	F	7.5±0.8 9.5±0.8	Diameter of Lead	d	0.55+0.06 -0.05
Feed Hole Position Capacitor Body	P2	6.35±1.3	Total Thickness of Tape	t	0.7±0.2
Feed Hole Position Capacitor Lead	P1	3.85±0.7	Thickness of Capacitor Body	T	Differ in each product
Diameter Of ISO	D	See table of each series	Alignment to FR. Direction	Δ h	0±2.0
			Length of snapped Lead	L	11.0 +0 -1.0
Width Of Base Tape	W	18.0±0.5	Width of Hold-down Tape	Wo	12.5
Feed Hole Vertical Position	W1	9.0 +0.75 -0.05	Hold-down Tape Position	W2	1.5±1.5
Taping Height	For Straight	Ho	Coating Extention	e	3.0 以下
	For Crimp	H		e1	up to center of crimp
		20 +1.5 -1.0			

AMMO PACK

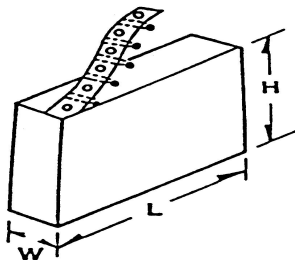

H = 241±5 mm
L = 332±5 mm
W = 42±3 mm

Acceptable to standard radial type cartridge.

REE

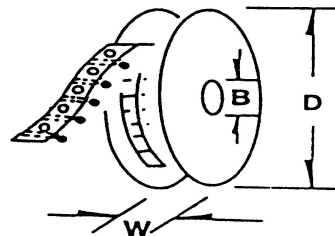

D ≦ 354(13.93)
B ≦ 21(.83")but
≦ 30(1.18")
W ≦ 55(2.16)

Acceptable to standard radial type cartridge with a few extra accessories. Reeled axials are also acceptable to standard axial type cartridge with a few accessories.