

REV.	ECN. No.	APPD.
A	BC-11-0128641	Yihsin Chen
B	BC-15-0002483	Yihsin Chen

NOTES: (UNLESS OTHERWISE SPECIFIED)

- DIMENSIONS SHALL BE INTERPRETED PER ASME 14.5-2009.
- MATERIAL AND FINISH:
 - HOUSING:

MATERIAL: GLASS FILLED HIGH TEMPERATURE THERMO-PLASTIC, COLOR BLACK UL 94V-0.

ASSEMBLY SHALL MEET ALL DIMENSIONS BEFORE AND AFTER EXPOSURE TO 225°C FOR 1 MINUTE. AFTER 235°C FOR 15 SECONDS AND 245°C FOR 10 SECONDS
 - SATA & 40PIN SAS PIN:
 - MATERIAL: COPPER ALLOY.
 - CONTACT AREA PLATING: GOLD PLATING OVER 50u" NICKEL
 - SOLDER TAIL: 75u" MIN TIN OVER 50u" NICKEL
 - PCI-e SAS PIN:
 - MATERIAL: COPPER ALLOY.
 - CONTACT AREA PLATING: GOLD PLATING OVER 50u" NICKEL
 - SOLDER TAIL PLATING: 75u" MIN TIN OVER 50u" NICKEL
- COMPONENT TO MEET SATA INDUSTRY STANDARD AND SEAGATE SPECIFICATION D9250004331.
- RESISTANCE TO SOLDERING:

235°C FOR 15 SECONDS AFTER 245° FOR 10 SECONDS.
- SPEC. OF PROD. ARE SHOWN ON DRAWING 303-0300-2883.
- MATERIALS OF PARTS ARE SHOWN ON DRAWING 303-0500-2883.
- SOLDER TAIL REQUIREMENTS:

ENTIRE DATA PIN IS TO BE PLATED. EXPOSED BASE METAL AT END OF SOLDERTAIL FABRICATION REQUIRES A SHEARING PROCESS, A SHEAR DIRECTION OF BOTTOM TO TOP OF SOLDERTAIL IS PREFERRED TO ALLOW FOR PLATING AT THE END OF TAIL

- ENVIRONMENTAL REQUIREMENTS: OPERATING TEMPERATURE RANGE; -40°C TO +125°C.
- HARMFUL MATERIAL CONTROL PLEASE FOLLOW FOXCONN'S DOC. NO. EPI12.
- THE CONCENTRATIONS OF Br&Cl CAN SATISFY THE REQUIREMENTS OF HALOGEN-FREE IN DOC. EPI12.
- THE "H" LOGO IS SPECIFIED BY DWG. NO. 998-0000-028 LOCATED APPROXIMATELY AS SHOWN WITH MAX.DEPH 0.10 mm BELOW SURFACE.
- DATE CODE: "****" AT APPROXIMATE LOCATION AS SHOWN
 THE DEFINITION PLEASE REFER TO FOXCONN DOC."SQ-3B0-070"
- DATUM A IS COINCIDENT WITH THE PLASTIC SURFACE COMPRISING THIS SIDE OF THE MATING TONGUE
- APPLIES TO CONTACT SURFACES OF ALL SOLDER TAILS.
- PRODUCT NO. MATRIX :

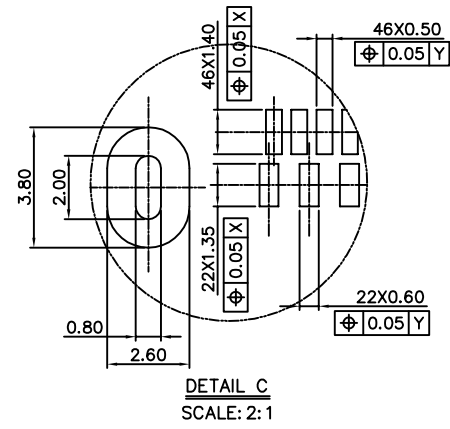
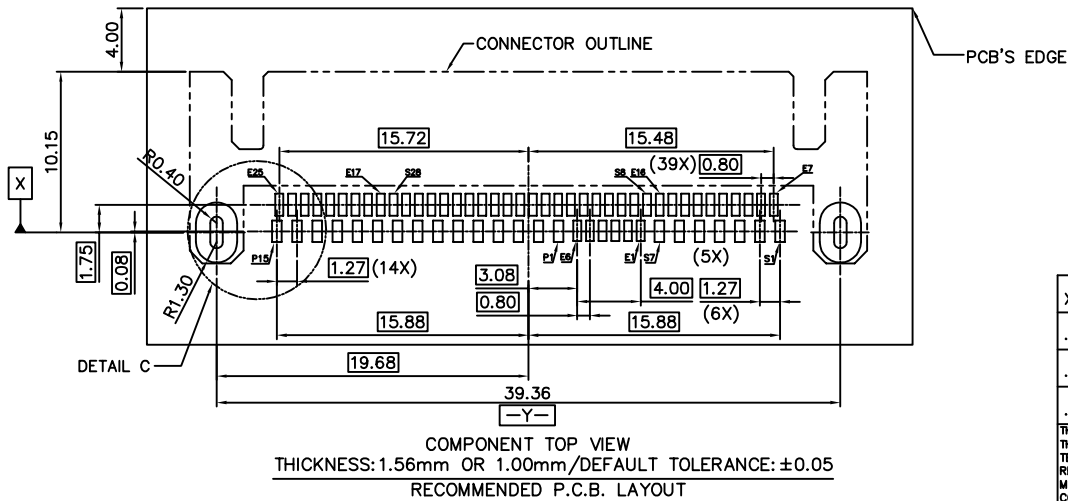
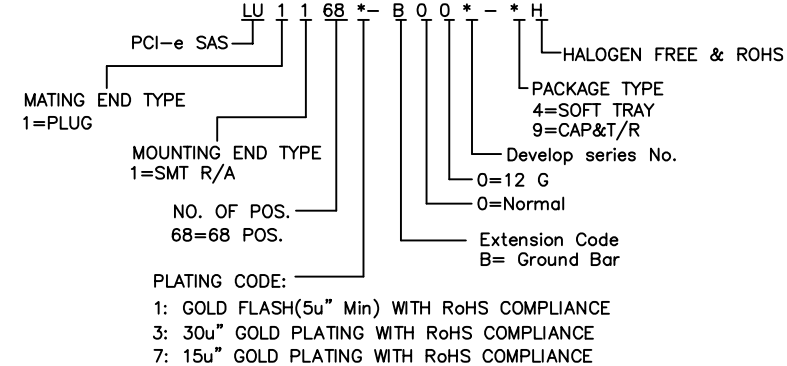

X.±	X'.± 2*	UNITS mm	NAME (INTENDED USE) PCI-e SAS	FOXCONN FOXCONN INTERCONNECT TECHNOLOGY LIMITED
.X± 0.20	.X'±	MAT'L	PART NO. (INTENDED USE) LU1168*-B00*-*H	
.XX± 0.15	.XX'±	FINISH	APPD: Yihsin Chen	CLASS: <input type="checkbox"/> CONFIDENTIAL <input type="checkbox"/> SECRET <input checked="" type="checkbox"/> GENERAL
.XXX± 0.10	.XXX'±		Q'TY	CHKD: Jimmy Hsiao
THESE DRAWINGS AND SPECIFICATIONS ARE THE PROPERTY OF FOXCONN INTERCONNECT TECHNOLOGY LIMITED AND SHALL NOT BE REPRODUCED, COPIED OR USED IN ANY MANNER WITHOUT THE PRIOR WRITTEN CONSENT OF FOXCONN INTERCONNECT TECHNOLOGY LIMITED.			APPD: Yihsin Chen	DWG NO.: 303-0000-2883
			DRAW: Zou Jianlong 1/8"15	SCALE SHEET REV. 1:1 1/4 B

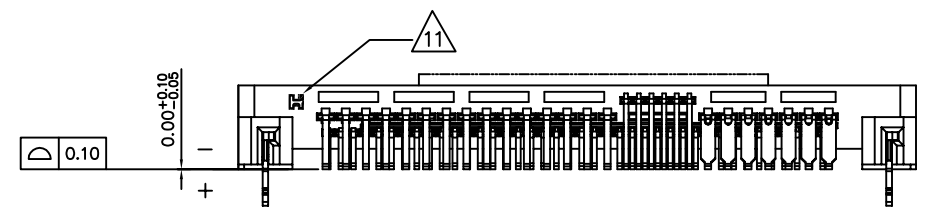
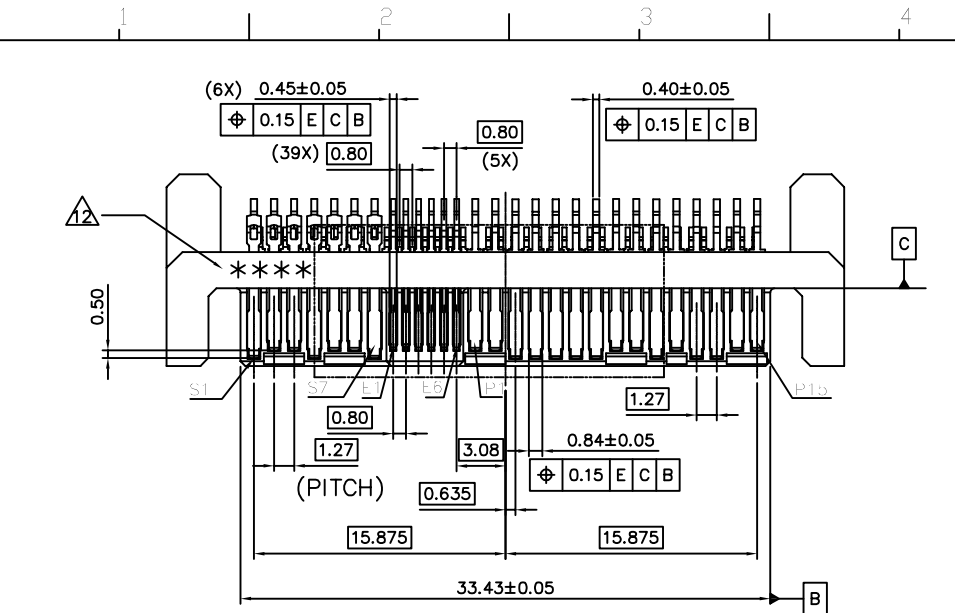

ALL THE SOLDER TAILS & STAND-OFF SURFACE

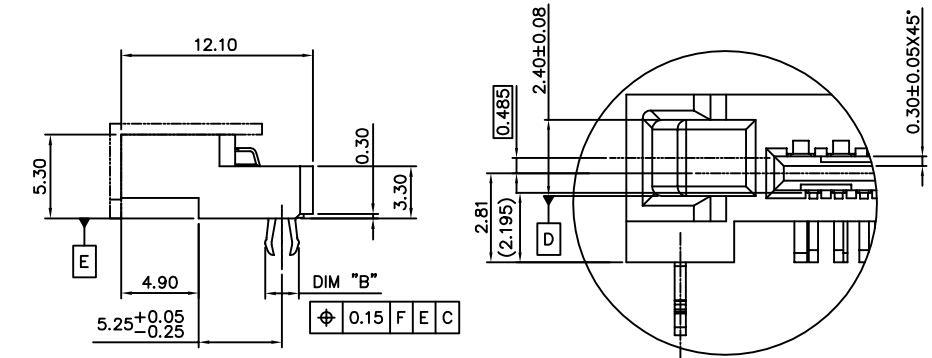
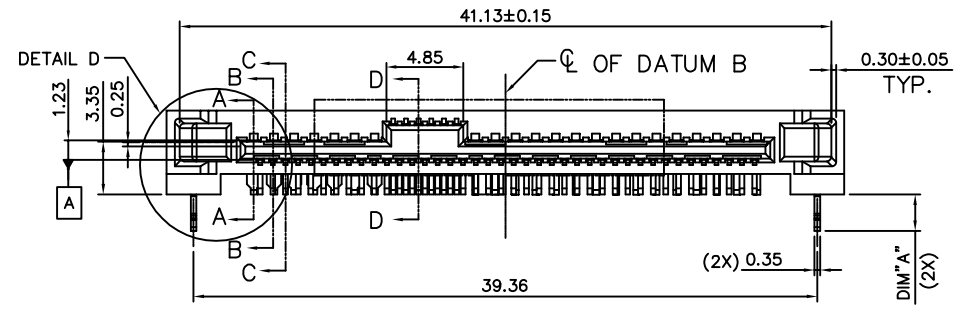

DETAIL D
SCALE: 2:1

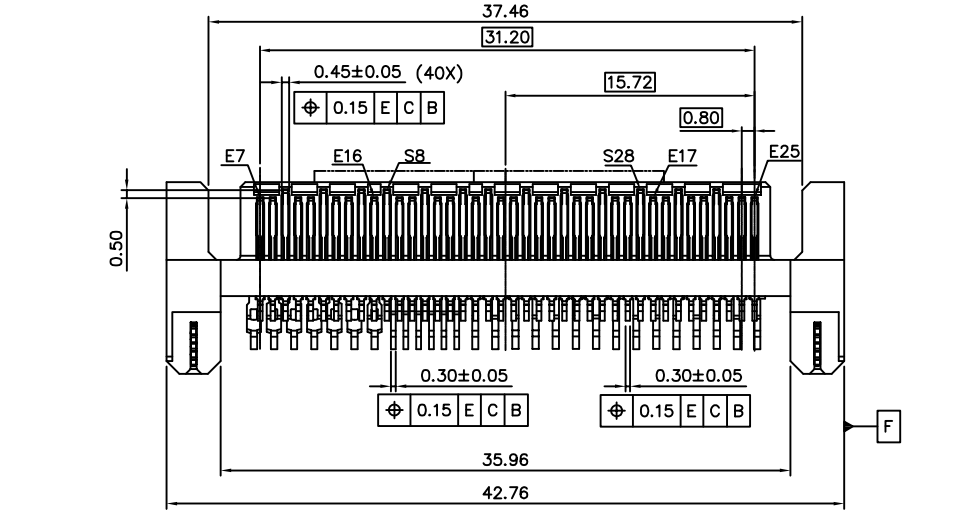

LU1168*-B007-*H	1.55+/-0.15	2.105+/-0.025	1.00
LU1168*-B001-*H	2.30+/-0.15	2.12+/-0.05	1.56
PRODUCT PART NO.	DIMENSION A	DIMENSION B	PCB THICKNESS

X.±	X.± 2*	UNITS mm	NAME (INTENDED USE) PCI-e SAS	FOXCONN FOXCONN INTERCONNECT TECHNOLOGY LIMITED
.X± 0.20	.X*±	MAT'L	PART NO. (INTENDED USE) LU1168*-B00*-*H	
.XX± 0.15	.XX*±	FINISH	APPD: Yihsin Chen	CLASS: <input type="checkbox"/> CONFIDENTIAL <input type="checkbox"/> SECRET <input checked="" type="checkbox"/> GENERAL
.XXX± 0.10	.XXX*±		CHKD: Jimmy Hsiao	TITLE: CUSTOMER DRAWING
THESE DRAWINGS AND SPECIFICATIONS ARE THE PROPERTY OF FOXCONN INTERCONNECT TECHNOLOGY LIMITED AND SHALL NOT BE REPRODUCED, COPIED OR USED IN ANY MANNER WITHOUT THE PRIOR WRITTEN CONSENT OF FOXCONN INTERCONNECT TECHNOLOGY LIMITED.			Q'TY	DWG NO.: 303-0000-2883
			DRAW: Zou Jianlong 1/8"15	SCALE SHEET REV. 1:1 2/4 B

REV.	ECN.	No.	APPD.
------	------	-----	-------

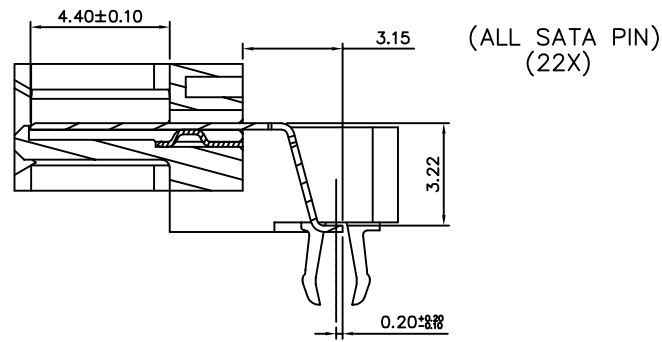

SECTION A-A
SCALE 2:1
(SATA GROUND PIN)

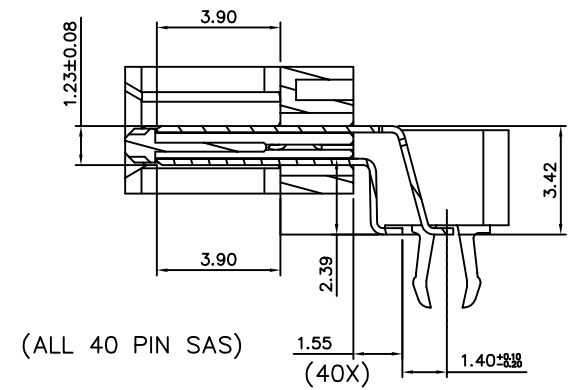

SECTION B-B
SCALE 2:1
(SATA LOW PIN & 40 PIN LOW PIN)

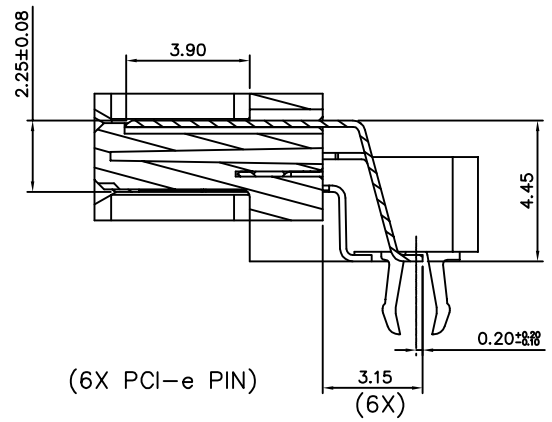

SECTION D-D
SCALE 2:1
(PCI-e PIN)

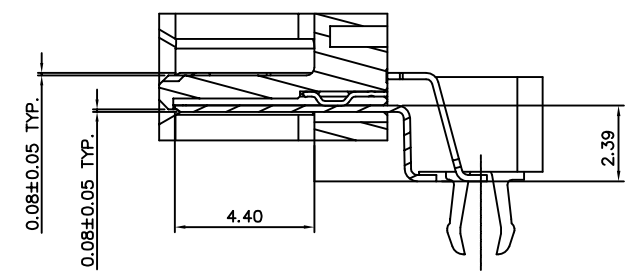

SECTION C-C
SCALE 2:1
(40 PIN GROUND PIN)

X.±	X.± 2*	UNITS mm	NAME(INTENDED USE) PCI-e SAS	FOXCONN [®] FOXCONN INTERCONNECT TECHNOLOGY LIMITED			
.X± 0.20	.X'±	MAT'L	PART NO.(INTENDED USE) LU1168*-B00*-*H				
.XX± 0.15	.XX'±	FINISH	APPD: Yihsin Chen	CLASS: <input type="checkbox"/> CONFIDENTIAL <input type="checkbox"/> SECRET <input checked="" type="checkbox"/> GENERAL			
.XXX±0.10	.XXX'±		Q'TY	CHKD: Jimmy Hsiao	TITLE: CUSTOMER DRAWING		
THESE DRAWINGS AND SPECIFICATIONS ARE THE PROPERTY OF FOXCONN INTERCONNECT TECHNOLOGY LIMITED AND SHALL NOT BE REPRODUCED, COPIED OR USED IN ANY MANNER WITHOUT THE PRIOR WRITTEN CONSENT OF FOXCONN INTERCONNECT TECHNOLOGY LIMITED.			DRAW: Zou Jianlong 1/8'15	DWG NO.: 303-0000-2883			
			<table border="1"> <tr> <td>SCALE</td> <td>SHEET</td> <td>REV.</td> </tr> <tr> <td>1:1</td> <td>3/4</td> <td>B</td> </tr> </table>		SCALE	SHEET	REV.
SCALE	SHEET	REV.					
1:1	3/4	B					

REV.	ECN.	No.	APPD.
------	------	-----	-------

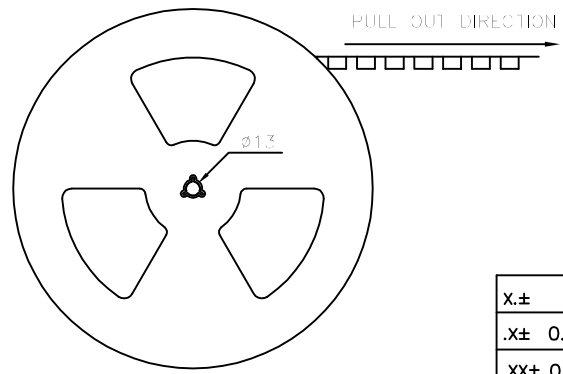
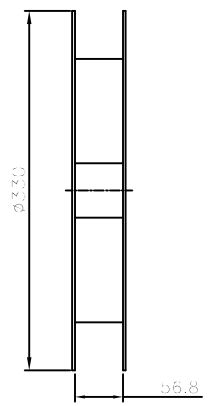
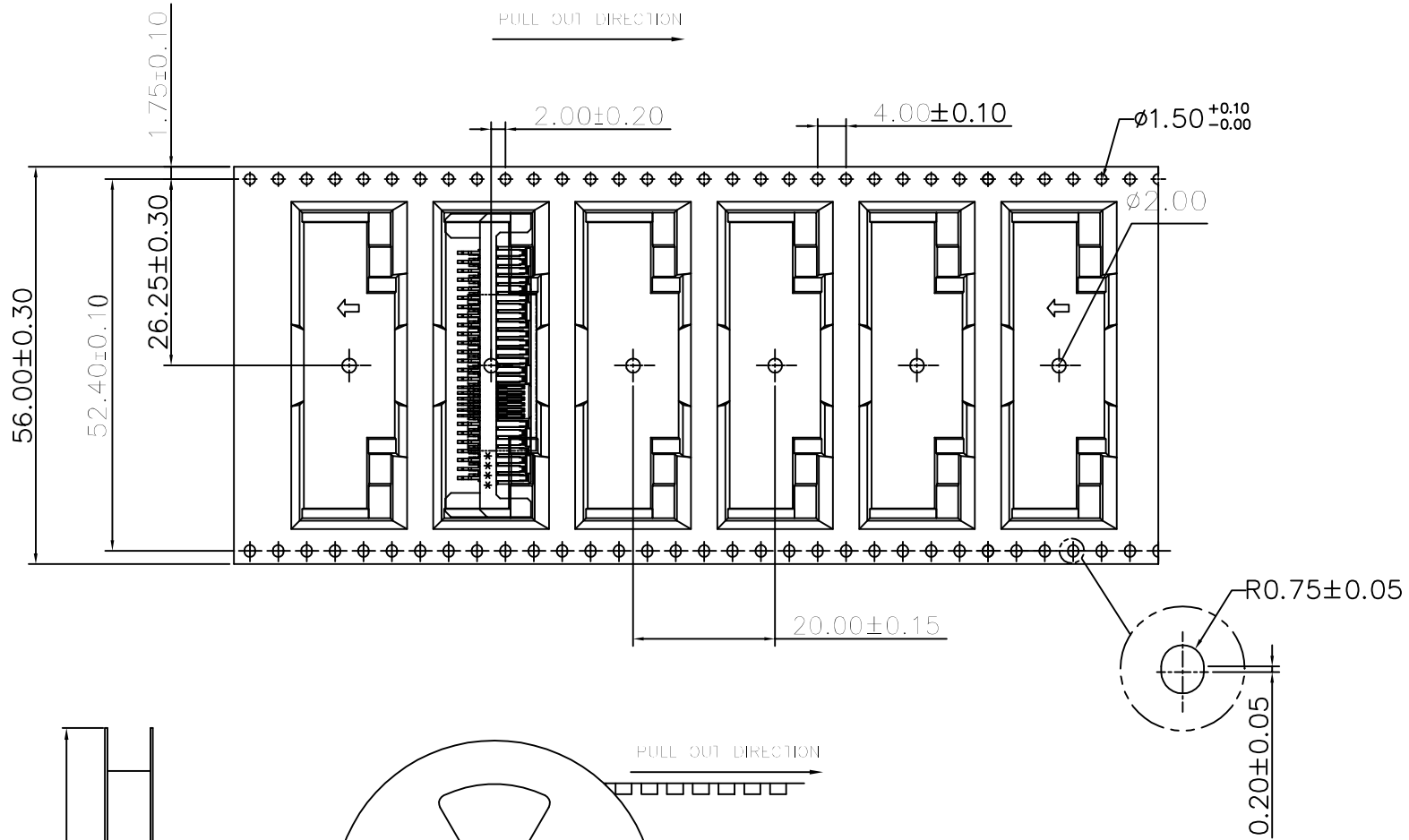

LU1168*-B007-9H	350	1750
LU1168*-B001-9H	350	1750
P/N	PCS/REEL	PCS/BOX

X.±	X'.± ±*	UNITS mm	NAME(INTENDED USE) PCI-e SAS	FOXCONN FOXCONN INTERCONNECT TECHNOLOGY LIMITED
.X± 0.20	.X'±	MAT'L	PART NO.(INTENDED USE) LU1168*-B00*-*H	
.XX± 0.15	.XX'±	FINISH	APPD: Yihsin Chen	CLASS: <input type="checkbox"/> CONFIDENTIAL <input type="checkbox"/> SECRET <input checked="" type="checkbox"/> GENERAL
.XXX±0.10	.XXX'±	Q'TY	CHKD: Jimmy Hsiao	TITLE: CUSTOMER DRAWING
THESE DRAWINGS AND SPECIFICATIONS ARE THE PROPERTY OF FOXCONN INTERCONNECT TECHNOLOGY LIMITED AND SHALL NOT BE REPRODUCED, COPIED OR USED IN ANY MANNER WITHOUT THE PRIOR WRITTEN CONSENT OF FOXCONN INTERCONNECT TECHNOLOGY LIMITED.			DRAW: Zou Jianlong 1/8'15	DWG NO.: 303-0000-2883

SPECIFICATIONS :

REV.	ECN NO.	APPD.
A	BC-11-0121609	Yihsin Chen
B	BC-15-0002501	Yihsin Chen

1. MATERIAL AND FINISH :

1-1. HOUSING & CAP :

HIGH TEMP. THERMOPLASTIC, UL94V-0 , COLOR BLACK.

1-2. S-ATA CONTACT :

COPPER ALLOY, 0.20 THICK. NICKEL PLATING OVER ALL, THICKNESS 50u" MIN.
MATTE-TIN PLATING OVER NICKEL, THICKNESS 75u" MIN. ON SOLDER AREA,
GOLD PLATING OVER NICKEL ON CONTACT AREA,

1-3. SAS CONTACT :

COPPER ALLOY, 0.20 THICK. NICKEL PLATING OVER ALL, THICKNESS 50u" MIN.
MATTE-TIN PLATING OVER NICKEL, THICKNESS 75u" MIN. ON SOLDER AREA,
GOLD PLATING OVER NICKEL ON CONTACT AREA,

1-4. PCI-e SAS PIN

COPPER ALLOY, 0.20 THICK. NICKEL PLATING OVER ALL, THICKNESS 50u"MIN.
MATTE-TIN PLATING OVER NICKEL, ON SOLDER AREA, THICKNESS 75u" MIN.
GOLD PLATING OVER NICKEL ON CONTACT AREA,

1-5. BOARD LOCK:

COPPER ALLOY, NICKEL PLATING OVER ALL, THICKNESS 50u" MIN.,
MATTE-TIN PLATING OVER ALL, THICKNESS 100u"MIN..

1-6. GROUND-BAR:

COPPER ALLOY, NICKEL PLATING OVER ALL, THICKNESS 50u" MIN.,
GOLD PLATING OVER NICKEL.

1-7. HARMFUL MATERIAL CONTROL PLAESE FOLLOW DOC. NO."EPI12"

1-8. THE CONCENTRATIONS OF Br&Cl CAN SATISFYTHE REQUIREMENTS OF HALOGEN-FREE IN DOC. EPI12.

2. ELECTRICAL :

2-1. LOW LEVEL CONTACT RESISTANCE : 30 MILLIOHMS MAX. INITIAL.

2-2. DIELECTRIC WITHSTANDING VOLTAGE : EIA-364-20, NO BREAKDOWN

2-3. INSULATION RESISTANCE : EIA-364-21, 1000 MEGAOHMS MIN.

2-4. TEMPERATURE RISE(VIA CURRENT CYCLING) POWER SECTION ONLY
(P1 THROUGH P15) : THE TEMPERATURE RISE SHALL NOT EXCEED 30°C

3. MECHANICAL:

3-1. MATING FORCE: EIA-364-13, 25N MAX.

3-2. UNMATING FORCE: EIA-364-13, 4.5N MIN. INITIAL AND AFTER DURABILITY

3-3. DURABILITY: 500 CYCLES

3-4. PHYSICAL SHOCK: PASS EIA-364-27, CONDITION H.

3-5. VIBRATION: PASS EIA-364-28, CONDITION VII TEST LETTER A.

4. ENVIRONMENTAL:

4-1. HUMIDITY: PASS EIA-364-31, METHOD II TEST CONDITION A.

4-2. OPERATING TEMPERATURE: -55° TO +85°.

4-3. TEMPERATURE LIFT:PASS EIA-364-17,TEST CONDITION III, METHOD A

4-4. MIXED FLOWING GAS:PASS EIA-364-65, CLASS 2A.

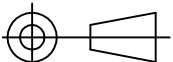
X.±	X.±	UNITS mm	NAME(INTENDED USE) PCI-e SAS	 FOXCONN INTERCONNECT TECHNOLOGY LIMITED.			
.X±	.X±	MAT'L	PART NO.(INTENDED USE) LU1168*-B00*-*H				CLASS: <input type="checkbox"/> CONFIDENTIAL <input type="checkbox"/> SECRET <input checked="" type="checkbox"/> GENERAL
.XX±	.XX±	FINISH	APPD: Yihsin Chen	TITLE: SPECIFICATION			
.XXX±	.XXX±		Q'TY	CHKD: Yusan Hsiao	DWG NO.: 303-0300-2883		
THESE DRAWINGS AND SPECIFICATIONS ARE THE PROPERTY OF FOXCONN INTERCONNECT TECHNOLOGY LIMITED.AND SHALL NOT BE REPRODUCED, COPIED OR USED IN ANY MANNER WITHOUT THE PRIOR WRITTEN CONSENT OF FOXCONN INTERCONNECT TECHNOLOGY LIMITED.					SCALE	SHEET	REV.
					1:1	1/1	B
			DRAW: Zou Jianlong 1/8'15				

ITEM	DESC.	Q'TY	MATERIAL	TREATMENT	REMARK
1	HOUSING	1	HIGH TEMPERATURE THERMO-PLASTIC, UL 94V-0	INJECTION MOLDING	
2	CAP	1			
3	SATA PIN	22	COPPER ALLOY	A) NICKEL PLATING OVER ALL THICKNESS : 50 u" MIN. B) MATTE-TIN PLATING OVER NICKEL.THICKNESS : 75 u" MIN ON SOLDER AREA C) GOLD PLATING OVER NICKEL. ON CONTACT AREA	
4	SAS PIN	40	COPPER ALLOY	A) NICKEL PLATING OVER ALL THICKNESS : 50 u" MIN. B) MATTE-TIN PLATING OVER NICKEL.THICKNESS : 75 u" MIN ON SOLDER AREA C) GOLD PLATING OVER NICKEL. ON CONTACT AREA	
5	PCI-e PIN	6	COPPER ALLOY	A) NICKEL PLATING OVER ALL THICKNESS : 50 u" MIN. B) MATTE-TIN PLATING OVER NICKEL.THICKNESS : 75 u" MIN ON SOLDER AREA C) GOLD PLATING OVER NICKEL. ON CONTACT AREA	
6	BOARD LOCK	2	COPPER ALLOY	A) NICKEL PLATING OVER ALL THICKNESS : 50u"MIN. B) MATTE-TIN PLATING OVER NICKEL. THICKNESS : 100u"MIN ON SOLDER AREA.	
7	GROUND BAR	1			

- NOTE : 1. HARMFUL MATERIAL CONTROL PLEASE FOLLOW DOC. NO. "EPI12"
2. THE CONCENTRATIONS OF Br&Cl CAN SATISFYTHE REQUIREMENTS OF HALOGEN-FREE IN DOC. EPI12.
3. PRODUCT NO. MATRIX:

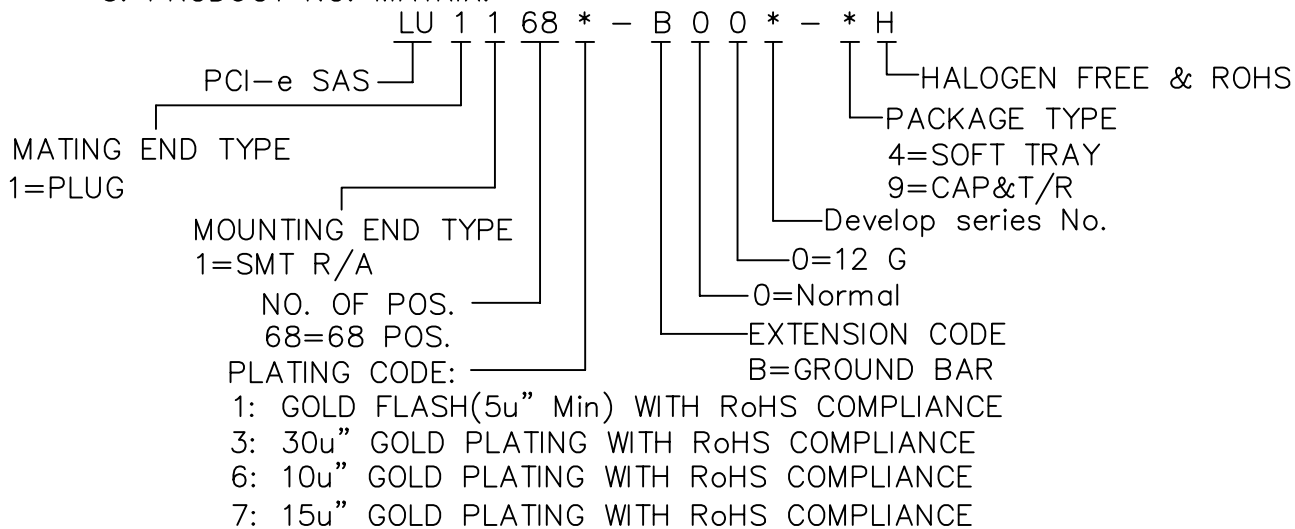

4. PLEASE CONTACT FOXCONN SALES REPRESENTATIVE TO VERIFY PRODUCT DETAILS&AVAILABILITY.

B	BC-15-0002533	Yihsin Chen
A	BC-11-0123512	Yihsin Chen
REV.	ECN NO	APPD.

X.±	X.*±	UNITS mm	NAME(INTENDED USE) PCI-e SAS	FOXCONN [®] FOXCONN INTERCONNECT TECHNOLOGY LIMITED.
.X±	.X*±	MAT'L	PART NO.(INTENDED USE) LU1168*-B00*-*H	
.XX±	.XX*±	FINISH	APPD: Yihsin Chen	CLASS: <input type="checkbox"/> CONFIDENTIAL <input type="checkbox"/> SECRET <input checked="" type="checkbox"/> GENERAL
.XXX±	.XXX*±		Q'TY	CHKD: Yusan Hsiao
THESE DRAWINGS AND SPECIFICATIONS ARE THE PROPERTY OF FOXCONN INTERCONNECT TECHNOLOGY LIMITED.AND SHALL NOT BE REPRODUCED, COPIED OR USED IN ANY MANNER WITHOUT THE PRIOR WRITTEN CONSENT OF FOXCONN INTERCONNECT TECHNOLOGY LIMITED.			DRAW: Zou Jianlong 1/8'15	DWG NO.: 303-0500-2883
		1:1		