

# 产品规格书

## SPECIFICATION FOR APPROVAL

CUSTOMER/客户名称: \_\_\_\_\_

MODEL NO./产品型号: BZ-C0805-G3-E1

DESCRIPTON./产品描述: CHIP 0805 翠绿



DATE./日期: 2020/06/06

版本 Edition: A.1

### CUSTOMER AUTHORIZED SIGNATURE/客户承认签核

--	--	--

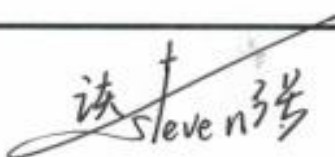
Please return to us one copy of "SPECIFICATION FOR APPROVAL" With your approved Signature./客户签字确认，盖章后请回传一份承认书我司。

核 准	审 核	制 定
		张 文 杰

Add: shenzhen baoan district rock street pond avenue macro hair tree  
Gao Xinyuan 12 5 floor of west side

地址：深圳市宝安区石岩街道塘头大道宏发佳特利高新园12栋5楼西侧

TEL/电话：0755-85255622

FAX/传真：0755-85255672

Http://www.cnbzic.com

■ Features:

1. 2.0mmx1.25mm SMT LED, 0.8mm THICKNESS.
2. WIDE VIEWING ANGLE.
3. IDEAL FOR BACKLIGHT AND INDICATOR.
4. Suitable for all SMT assembly
5. ROHS compliant
6. Lens Color:Water Clear

■ Applications:

1. Automotive: backlighting in dashboard and switch.
2. Telecommunication: indicator and back-lighting in telephone and fax.
3. Flat backlight for LCD switch and symbol.

■ Outline Dimension:

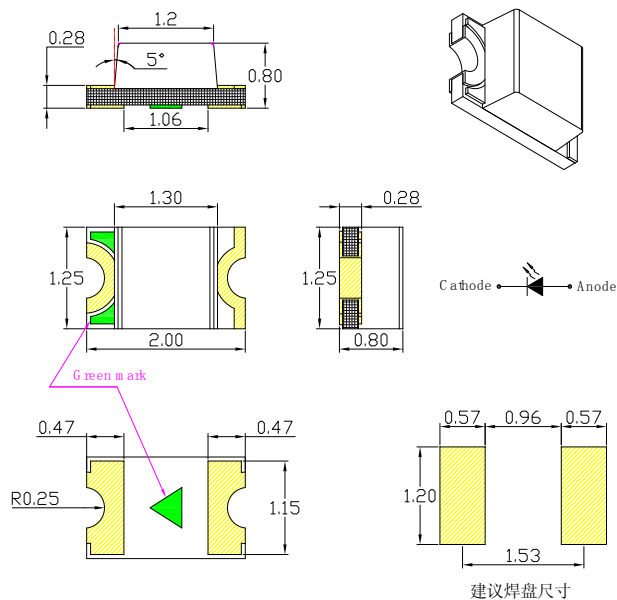

Notes:

1. All dimensions are in millimeters.
2. Tolerance is  $\pm 0.1$  unless otherwise noted.
3. Specifications are subject to change without notice.

■ Typical Electrical & Optical Characteristics(Ta=25° )

Items	Symbol	Condition	Min	Typ	Max	Unit
Forward Voltage	$V_F$	$I_F = 5\text{mA}$	2.6	---	3.2	V
Reverse Current	$I_R$	$V_R = 5\text{V}$	0	---	1	$\mu\text{A}$
Wave Length	$\lambda_d$	$I_F = 5\text{mA}$	---	522.5	---	nm
Luminous Intensity	$I_v$	$I_F = 5\text{mA}$	160	250	331	mcd
View Angle	$2\theta_{1/2}$	$I_F = 5\text{mA}$	---	120	---	Deg

■ Absolute Maximum Ratings (Ta = 25°C)

Items	Symbol	Absolute maximum Rating	Unit
Power Dissipation	PD	80	mW
Forward Current(DC)	$I_F$	25	mA
Peak Forward Current	$I_{FP}$	100	mA
Reverse Voltage	$V_R$	5	V
Electrostatic Discharge	ESD	2000 (HBM)	V
Operation Temperature	Topr	- 40~ + 85	°C
Storage Temperature	Tstg	- 40~ + 85	°C

Note :1/10 Duty Cycle, 0.1 ms Pulse Width

■ Typical Electrical/Optical Characteristics Curves:

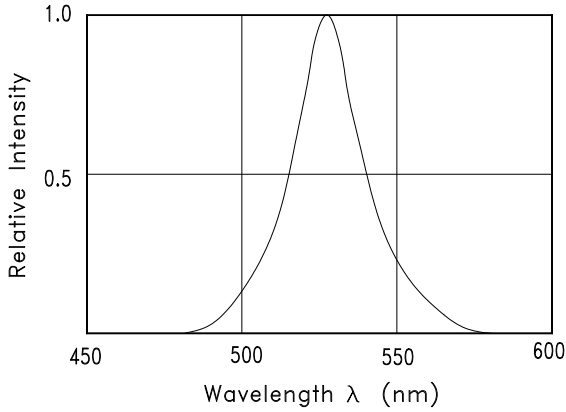

Fig.1 RELATIVE INTENSITY VS. WAVELENGTH

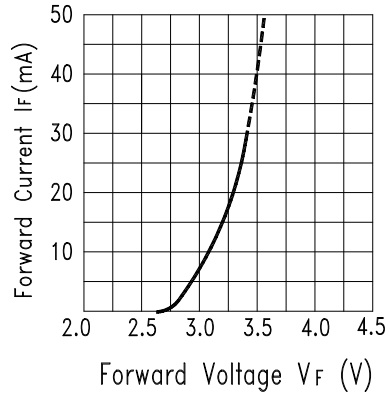

Fig.2 Forward Current vs. Forward Voltage

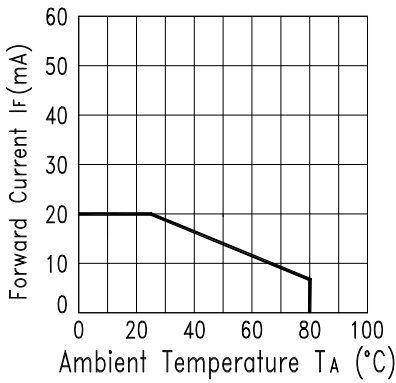

Fig.3 Forward Current Derating Curve

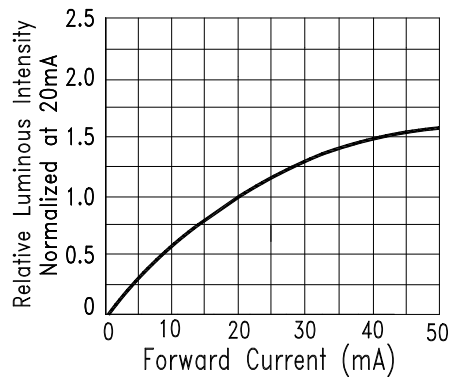

Fig.4 Relative Luminous Intensity vs. Forward Current

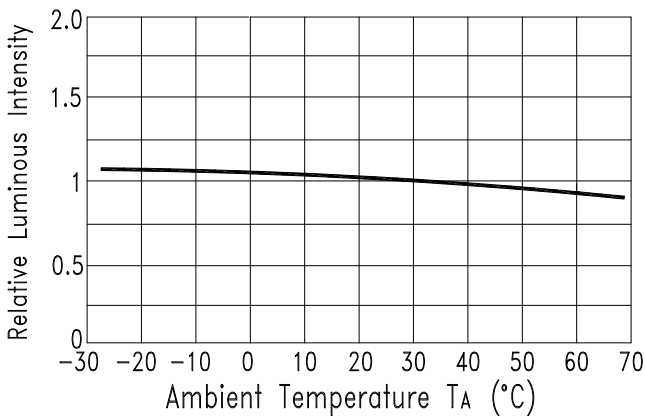

Fig.5 Luminous Intensity vs. Ambient Temperature

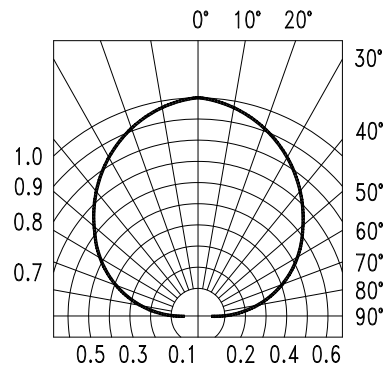

Fig.6 Spatial Distribution

## ■ Reliability Test

Number	Test Item	Test Conditions	Sample size	Acceptance/Rejection
1	Reflow Solder	Temperature: Max 260 °C Time: 10S Cycles : 3times	22PCS	0/1
2	Life Test	Temperature=25 °C ±5 °C Current=20mA ±2mA Cycles: 10000H	22PCS	0/1
3	Temperature Cycling	85°C ~ 25°C ~ -40°C ~ 25°C 30min 5min 30min 5min Cycles: 100	22PCS	0/1
4	Hot/cold Temperature Shock	100 °C ±5 °C ~ -40 °C ±5 °C 15 mins 15 mins Cycles: 100	22PCS	0/1
5	Low Temperature Storage	Temperature: -40 °C ±5 °C Cycles: 1000H	22PCS	0/1
6	High Temperature Storage	Temperature: 100 °C ±5 °C Cycles: 1000H	22PCS	0/1

Remarks: Specifications are subject to change without prior notice.

## ■ Reflow soldering instructions

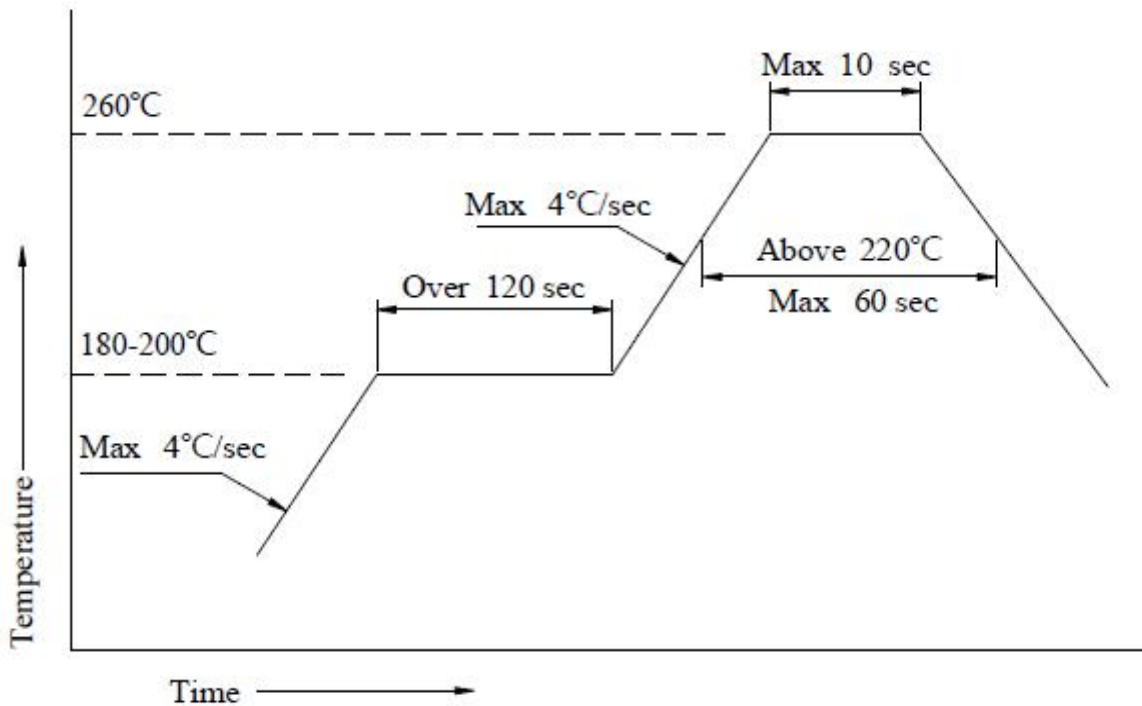

- 1、Reflow soldering is recommended to the use of clean free flux, and in accordance to the reflow curve. Maximum number of soldering is limited
- 2、When soldering, do not exert pressure during heating process.

## ■ Soldering

- 1、When manual soldering iron is used, it is recommended to use 20W anti-electro static soldering iron, soldering temperature must be kept below  $360^{\circ}\text{C}$  / 3 seconds, 1Time soldering only
- 2、Do not mix different BIN materials on the same board, otherwise it will cause LED color Variation

## ■ Taping Specifications (Unit: mm)

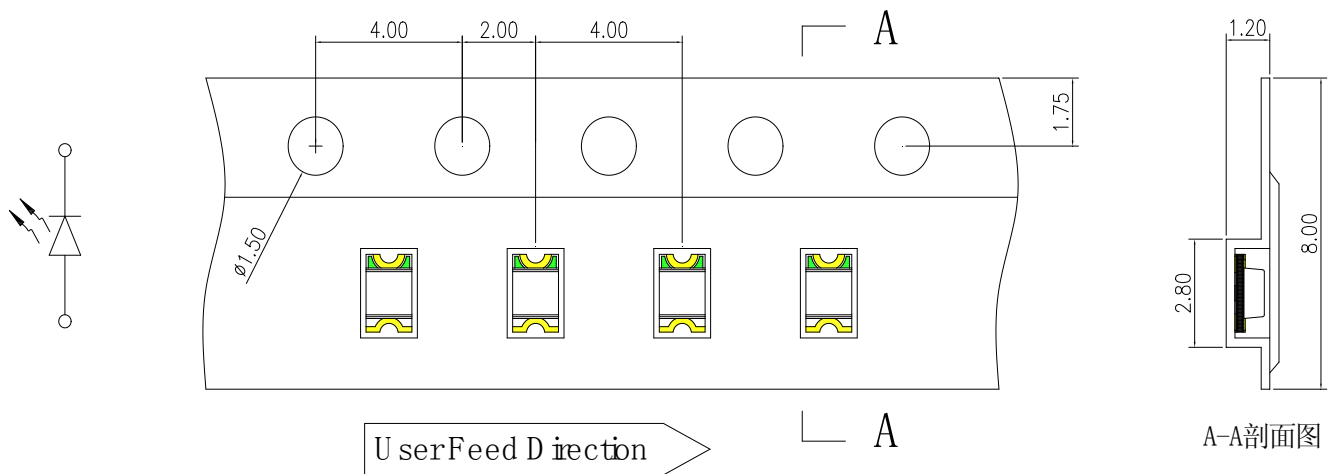

## ■ Reel Size (Unit: mm)

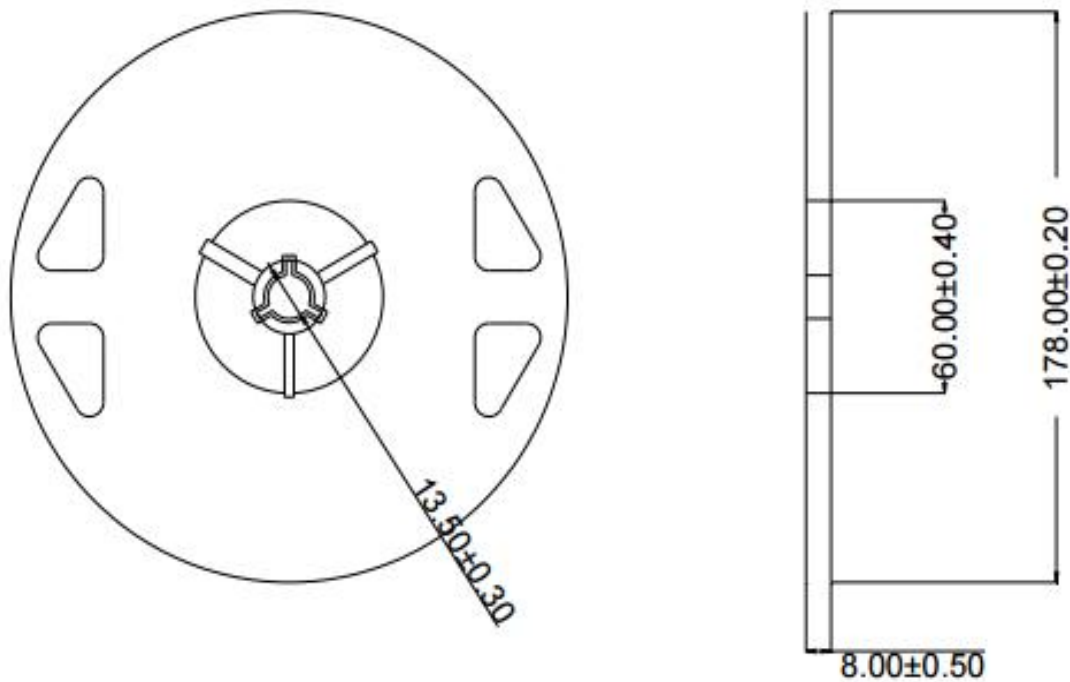

## ■ Humidity Proof packaging

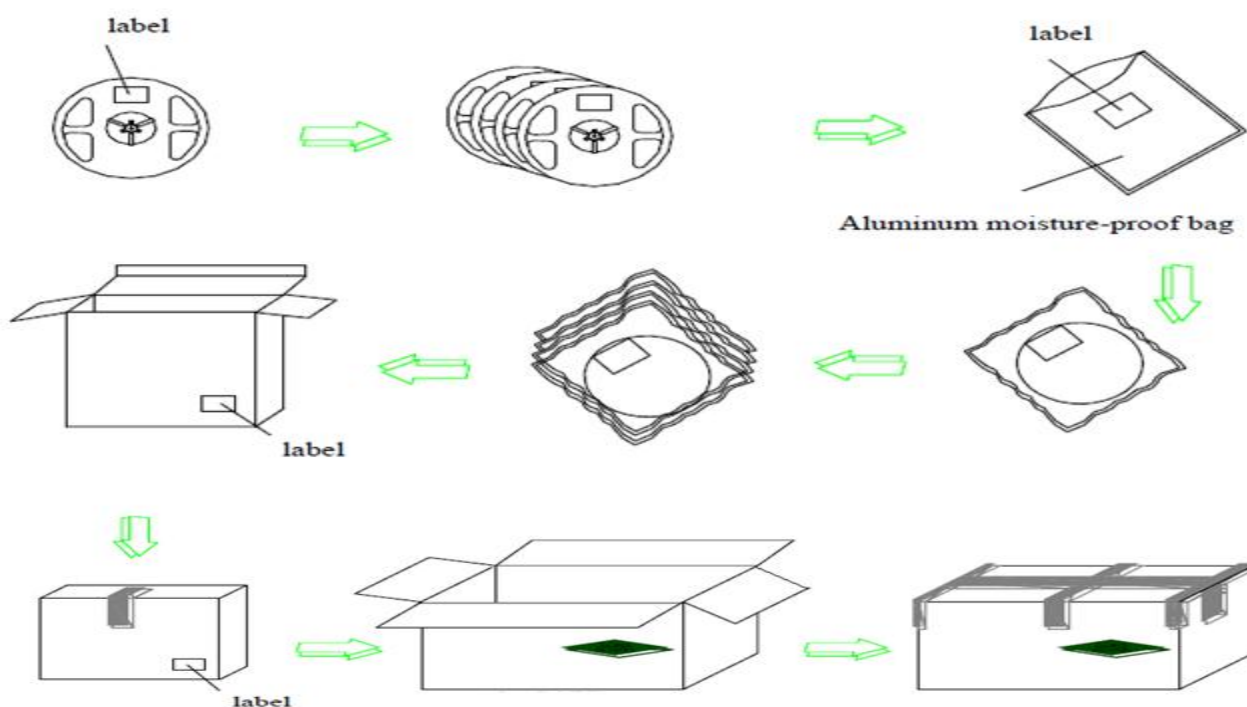

### Note:

- In order to avoid the absorption of moisture, it is recommended to store in the dry box (or desiccator) with a desiccant. Otherwise, to store them in the following environment is recommended.

Temperature: 5°C~30°C

Humidity: 60%HR max.

- Attention after opened

However LED is corresponded SMD, when LED be soldered dip, interfacial separation may affect The light transmission efficiency, causing the light intensity to drop. Attention in followed.

a. After opened and mounted, the soldering shall be quickly.

b. Keeping of a fraction

Temperature: 5°C~40°C

Humidity: less than 30%

- In case or more than 1 week passed after opening or change color of indicator on desiccant components shall be dried 10-12hr. at 80°C±3°C.

- In case of supposed the components is humid, shall not be dried dip-solder just before. 100Hr at 80°C±3°C or 12Hr at 100°C±3°C