



BCT3756

High Efficiency, Support 0.3% PWM Dimming Boost WLED Driver

BCT3756

High Efficiency, Support 0.3% PWM Dimming Boost WLED Driver

GENERAL DESCRIPTION

The BCT3756 is a white LED driver with integrated boost converter. With an internal 38V switch FET, the BCT3756 drives up a string of up to 10 LEDs in series. The boost converter runs at 1.1MHz fixed switching frequency to reduce output ripple, improve conversion efficiency, and allows for the use of small external components.

The default white LED current is set with the external sense resistor RSET, and the feedback voltage is regulated to 200mV, as shown in the typical application. During the operation, a pulse width modulation (PWM) signal can be applied to the CTRL pin through which the duty cycle determines the feedback reference voltage.

BCT3756 integrates built-in soft-start function to minimize the power supply inrush current. BCT3756 also integrates over-current protection, LED open protection and over temperature protection(OTP) to prevent chip from entering abnormal operating conditions.

FEATURES

- Support 0.3% PWM dimming
- 1.1MHz Switching Frequency
- 38V Over-voltage Protection for up to 10 LEDs in Series
- 200mV Reference Voltage
- 2.7V to 5.5V Input Voltage Range
- Over-current and Over-temperature Protection
- Built-in Soft-start Limits Inrush Current
- Package DFN2x2-6L

APPLICATIONS

- Cellular Phones
- Ultra Mobile Devices
- Portable Media Players
- PDAs, GPS Receivers
- White LED Backlighting

ORDERING INFORMATION

Order Number	Package Type	Temperature Range	Marking	QTY/Reel
BCT3756ELT-TR	DFN2x2-6L	-40°C to +85°C	3756 XXXX	3000

Note:

"XXXX" in Marking will be appeared as the batch code.

PIN CONFIGURATION

Top View

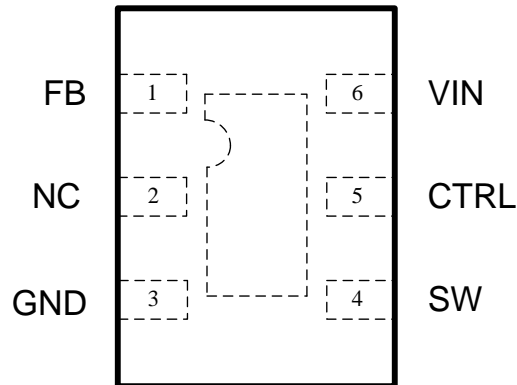

PIN DESCRIPTION

NO.	NAME	I/O	DESCRIPTION
1	FB	I	Feedback pin for current. Connect the sense resistor from FB to GND.
2	NC	-	No Connect
3	GND	G	Ground.
4	SW	I	This is the switching node of the IC. Connect the inductor between the VIN and SW pin. This pin is also used to sense the output voltage for open LED protection.
5	CTRL	I	Control pin of the boost regulator. It is a multi-functional pin which can be used for enable control and digital dimming.
6	VIN	I	The input supply pin for the IC. Connect VIN to a supply voltage between 2.7V and 5.5V.
-	Thermal Pad	-	The thermal pad should be soldered to the analog ground plane. If possible, use thermal via to connect to ground plane for ideal power dissipation.

Typical Application Circuit

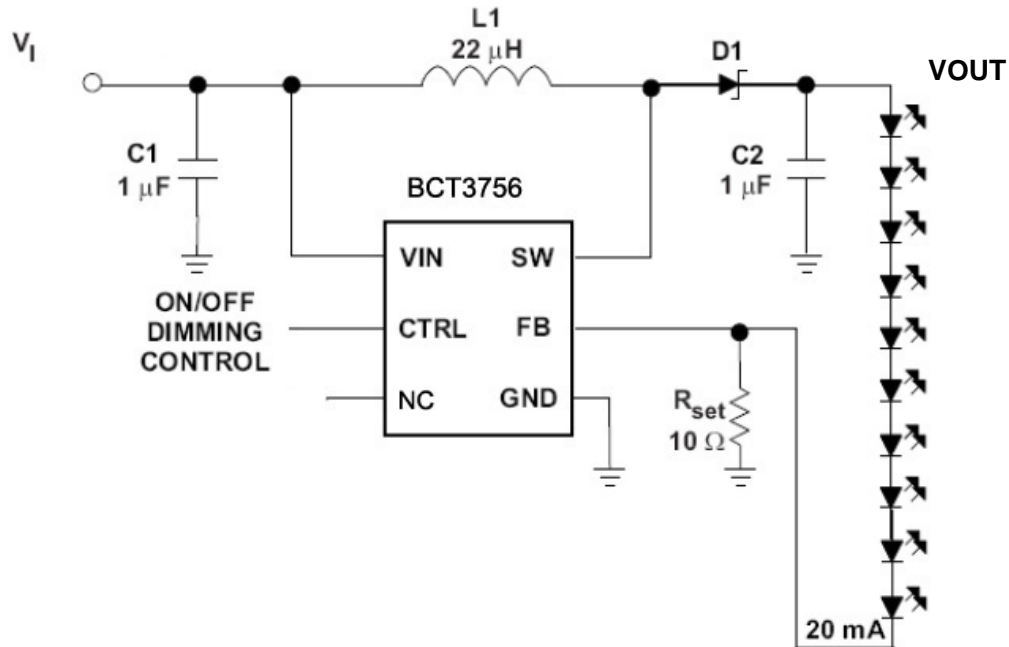

ABSOLUTE MAXIMUM RATINGS⁽¹⁾

PARAMETERS	RANGE
Supply voltage range $V_{IN}^{(2)}$	-0.3V to 6V
Voltage on FB, CTRL ⁽²⁾	-0.3V to 6V
Voltage on SW ⁽²⁾	-0.3V to 40V
Junction-to-ambient thermal resistance θ_{JA}	140°C/W
Operating free-air temperature range	-40°C to 85°C
Operating Junction temperature T_J	-40°C to 150°C
Storage temperature T_{STG}	-65°C to 150°C
Lead Temperature (Soldering 10 Seconds)	260°C
ESD	
ALL PINS HBM (human body model)	±3000V
ALL PINS CDM (charge device model)	±2000V
Latch-up	
Latch-up current maximum rating per JEDEC standard	+IT: 450mA -IT: -450mA



BCT3756

High Efficiency, Support 0.3% PWM Dimming Boost WLED Driver

(1) Conditions out of those ranges listed in "absolute maximum ratings" may cause permanent damages to the device. In spite of the limits above, functional operation conditions of the device should within the ranges listed in "recommended operating conditions". Exposure to absolute-maximum-rated conditions for prolonged periods may affect device reliability.

(2) All voltage values are with respect to network ground terminal.

RECOMMENDED OPERATING CONDITIONS

Symbol	Description	MIN	TYP	MAX	UNIT
V _{IN}	Input voltage range, V _{IN}	2.7		5.5	V
L	Inductor ⁽¹⁾	10		22	μH
C _{IN}	Input capacitor	1		10	μF
C _O	Output capacitor ⁽¹⁾	0.47		10	uF
T _A	Operating ambient temperature	-40		85	°C
T _J	Operating junction temperature	-40		125	°C

(1) These values are recommended values that have been successfully tested in several applications. Other values may be acceptable in other applications but should be fully tested by the user.

DISSIPATION RATINGS

R _{qJC}	R _{qJA}	DERATING FACTOR ABOVE T _A = 25°C	T _A < 25°C	T _A = 70°C	T _A = 85°C
20°C/W	140°C/W	7.1 mW/°C	893 mW	571 mW	464 mW



BCT3756

High Efficiency, Support 0.3% PWM Dimming Boost WLED Driver

ELECTRICAL CHARACTERISTICS

Test Condition: TA = 25°C, VIN = 3.6V, VCTRL = VIN (Unless otherwise specified).

PARAMETER		TEST CONDITION	MIN	TYP	MAX	UNIT
SUPPLY VOLTAGE AND CURRENT						
VIN	Input voltage range		2.7		5.5	V
VUVLO	Under-voltage lockout threshold	VIN falling		2.2	2.39	V
VHYS	Under-voltage lockout hysteresis			100		mV
ISD	Shutdown current	VCTRL = GND, VIN=4.2V		0.1	1	μA
IQ	Operating quiescent current	VFB = 1V		250		μA
PWM DIMMING CONTROL						
fPWM	Frequency of PWM dimming		10		100	kHz
DPWM	PWM dimming duty cycle		0.3		100	%
tMIN_ON	Minimum on pulse width			50		ns
VOLTAGE AND CURRENT CONTROL						
VREF	Voltage feedback regulation voltage		194	200	205	mV
VREF_PWM	Voltage feedback regulation voltage under brightness control	PWM duty cycle = 1%		2.25		mV
		PWM duty cycle = 0.3%		0.6		mV
IFB	Voltage feedback input bias current			0.1	1	μA
BOOST CONVERTER						
RDS(on)	N-channel MOSFET on-resistance	VIN = 3.6V		0.4	0.7	Ω
		VIN = 3.0V			0.7	Ω
fS	Oscillator frequency			1100		kHz
DMAX	Maximum duty cycle		90	93		%
OCP AND OVP						
ILIM	N-channel MOSFET current limit			1.5		A
VOVP	Open LED overvoltage protection threshold	Measured on the SW pin		38		V

CTRL INTERFACE						
V _{CTRL_H}	CTRL logic high voltage	V _{IN} = 2.7V to 5.5V	1.4			V
V _{CTRL_L}	CTRL logic low voltage	V _{IN} = 2.7V to 5.5V			0.4	V
R _{CTRL}	CTRL pull down resistor			600		kΩ
t _{OFF}	CTRL pulse width to shutdown	CTRL high to low	2.5			ms
THERMAL SHUTDOWN						
T _{OTP}	Thermal shutdown threshold			165		°C
T _{HYS}	Thermal shutdown threshold hysteresis			15		°C

Function Block Diagram

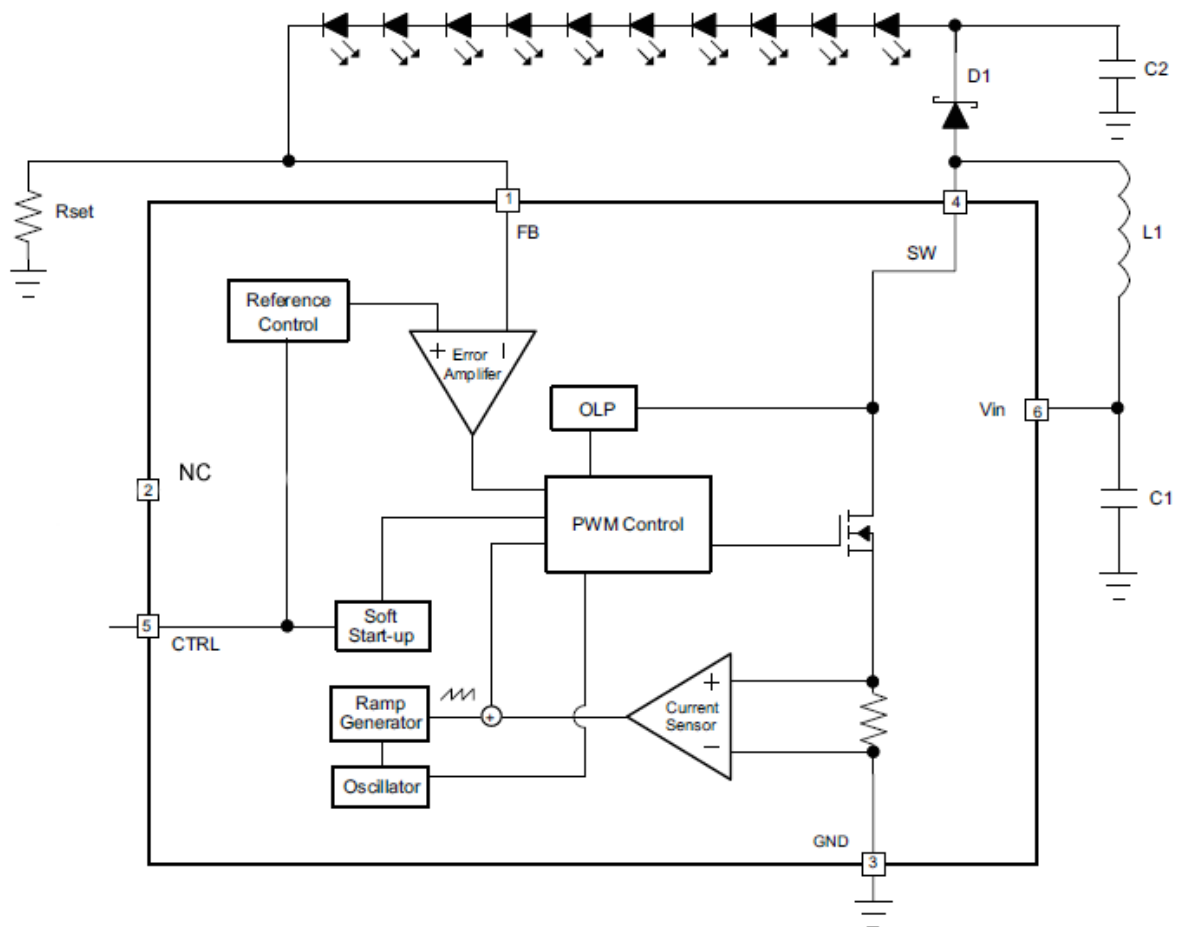



BCT3756

High Efficiency, Support 0.3% PWM Dimming Boost WLED Driver

DETAILED DESCRIPTION

OPERATION

The BCT3756 is a high efficiency, high output voltage boost converter in small package size. The device is ideal for driving up to 10 white LEDs in series. The serial LED connection provides even illumination by sourcing the same output current through all LEDs. The device integrates 38V/2A switch FET and operates in pulse width modulation (PWM) with 1.1MHz fixed switching frequency. The duty cycle of the converter is set by the error amplifier output and the current signal applied to the PWM control comparator. The control architecture is based on traditional current-mode control. Therefore, slope compensation is added to the current signal to allow stable operation for duty cycle larger than 50%. The feedback loop regulates the FB pin to a low reference voltage (200mV typical), reducing the power dissipation in the current sense resistor.

SOFT START-UP

Soft-start circuitry is integrated into the IC to avoid a high inrush current during start-up. After the device is enabled, the voltage at FB pin ramps up to the reference voltage. This ensures that the output voltage rises slowly to reduce the input current.

OPEN LED PROTECTION

Open LED over-voltage protection circuitry prevents IC damage as the result of white LED disconnection. The BCT3756 monitors the voltage at the SW pin during each switching cycle. The circuitry turns off the switch FET as soon as the SW voltage exceeds the VOVP threshold for 8 clock cycles.

SHUTDOWN

The CTRL input is used to enable or disable the BCT3756. Pulling the CTRL pin higher than 1.4V will enable the device. The BCT3756 has an internal shutdown delay circuitry, when the CTRL pin is held low for an amount of time longer than 2.5ms, the BCT3756 will enter shutdown mode and the input supply current for the device is less than 1μA. Although the internal FET does not switch in shutdown, there is still a DC current path between the input and the LEDs through the inductor and Schottky diode. The minimum forward voltage of the LED array must exceed the maximum input voltage to ensure that the LEDs remain off in shutdown. However, in the typical application with two or more LEDs, the forward voltage is large enough to reverse bias the Schottky and keep leakage current low.

UNDER-VOLTAGE LOCKOUT

An under-voltage lockout prevents operation of the device at input voltage below typical 2.2V. When the input voltage is below the under-voltage threshold, the internal switch FET is turned off. If the input voltage rises by under-voltage lockout hysteresis, the IC restarts.

CURRENT PROGRAM

The loop of Boost structure will keep the FB pin voltage equal to the reference voltage V_{FB} . Therefore, when R_{set} connects FB pin and GND, the current flows from V_{OUT} through LED and R_{set} to GND will be decided by the current on R_{set} , which is equal to following equation:

$$I_{LED} = V_{FB} / R_{set}$$

Where

I_{LED} =output current of LEDs

V_{FB} =regulated voltage of FB

R_{set} =current sense resistor

PWM BRIGHTNESS DIMMING

When the CTRL pin is constantly high, the FB voltage is regulated to 200mV typically. However, the CTRL pin allows a PWM signal to reduce this regulation voltage, it achieves LED brightness dimming. The relationship between the duty cycle and the FB voltage is given by the following equation:

$$V_{FB} = \text{Duty} \times 200\text{mV}$$

Where:

Duty = duty cycle of the PWM signal

200mV = internal reference voltage

The IC chops up the internal 200mV reference voltage at the duty cycle of the PWM signal. The pulse signal is then filtered by an internal low pass filter. The output of the filter is connected to the error amplifier as the reference voltage for the FB pin regulation. Therefore, although a PWM signal is used for brightness dimming, only the WLED DC current is modulated, which is often referred as analog dimming. This eliminates the audible noise which often occurs when the LED current is pulsed in replica of the frequency and duty cycle of PWM control. Unlike other scheme which filters the PWM signal for analog dimming, BCT3756 regulation voltage is independent of the PWM logic voltage level which often has large variations.

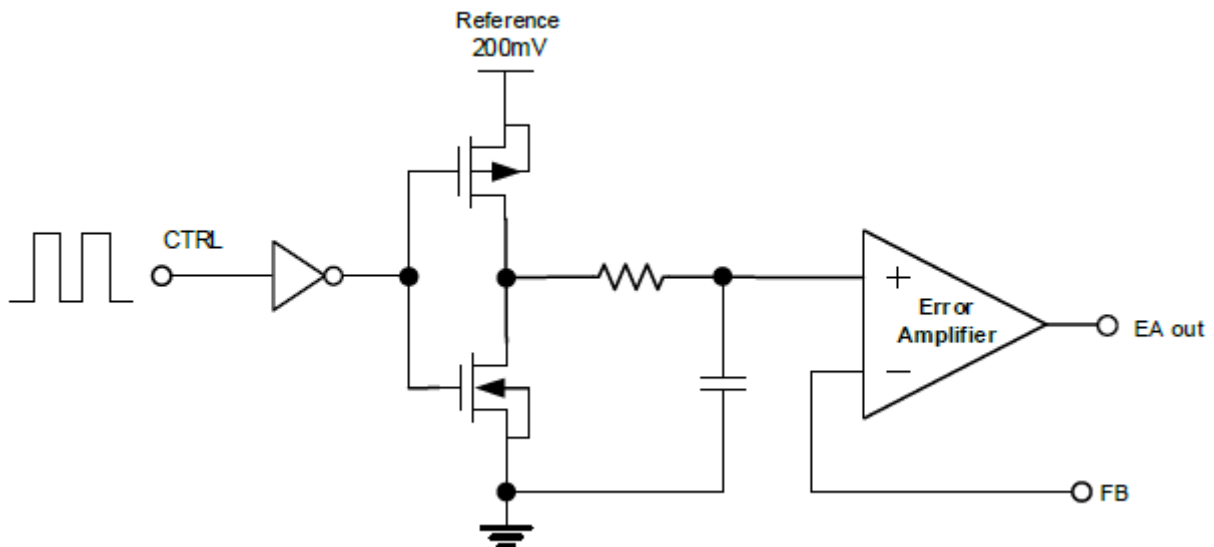

THERMAL SHUTDOWN

An internal thermal shutdown turns off the device when the typical junction temperature of is exceeded 165°C. The device is released from shutdown automatically when the junction temperature decreases by 15°C.

APPLICATION INFORMATION

MAXIMUM OUTPUT CURRENT

The over-current limit in a boost converter limits the maximum input current and thus maximum input power for a given input voltage. Maximum output power is less than maximum input power due to power conversion losses. The current limit setting, input voltage, output voltage and efficiency can all change maximum current output. Therefore, the ripple has to be subtracted to derive maximum DC current. The ripple current is a function of switching frequency, inductor value and duty cycle. The following equations take into account of all the above factors for maximum output current calculation.

$$I_P = \frac{1}{L \times F_S \times \left(\frac{1}{V_{OUT} + V_F - V_{IN}} + \frac{1}{V_{IN}} \right)}$$

Where:

I_P = inductor peak to peak ripple L = inductor value

V_F = Schottky diode forward voltage

F_S = switching frequency

V_{OUT} = output voltage of the boost converter. It is equal to the sum of V_{FB} and the voltage drop across LEDs.

$$I_{OUT_MAX} = \frac{V_{IN} \times (I_{LIM} - I_P/2) \times \eta}{V_{OUT}}$$

Where:

I_{OUT_MAX} = maximum output current of the boost converter

I_{LIM} = over-current limit, for worst case calculation the minimum value has to be chosen.

η = efficiency

INDUCTOR SELECTION

Inductor value, saturation current, and Direct Current Resistance (DCR) are the most important parameters used to select an inductor for the BCT3756.

The suitable inductance range for this device is 10 μ H to 22 μ H. Higher inductance lowers the value of the RMS current of the step-up converter. Together with a lower DCR value of the inductor, the total inductor power loss becomes much lower. Considering inductor size and cost, 10 μ H inductance is recommended. The below table lists some recommended inductors for the BCT3756.

Recommend Inductors

Part Number	L(μ H)	DCR MAX (Ω)	Saturation Current (mA)	Size(L x W x H mm)	Vendor
LQH3NPN100NM0	10	0.3	750	3x3x1.5	Murata
VLCF5020T-220MR75-1	22	0.4	750	5x5x2.0	TDK
CDH3809/SLD	10	0.3	570	4x4x1.0	Sumida
A997AS-220M	22	0.4	510	4x4x1.8	TOKO

SCHOTTKY DIODE SELECTION

The high switching frequency of the BCT3756 demands a high-speed rectification for optimum efficiency. Ensure that the diode average and peak current rating exceeds the average output current and peak inductor current. In addition, the



BCT3756

High Efficiency, Support 0.3% PWM Dimming Boost WLED Driver

diode's reverse breakdown voltage must exceed the open LED protection voltage. To achieve better efficiency, a low VF Schottky diode is recommended. ONsemi MBR0540 and ZETEX ZHCS400 are recommended for the BCT3756.

OUTPUT CAPACITOR SELECTION

The output capacitor is mainly selected to meet the requirements for the output ripple and loop stability.

The output voltage of the BCT3756 could reach up to 38V. X7R type output capacitor rated of 50 V is suggested. To reduce power loss, a ceramic capacitor with a low Effective Series Resistance (ESR) is better. The capacitor in the range of 0.47uF to 10uF is recommended for input side. The recommended output capacitor value is 1uF.

PCB LAYOUT CONSIDERATION

For best performance of the BCT3756, the following guidelines must be followed.

1. Input /Output capacitors should be placed close to the IC and connected to ground to reduce noise coupling.
2. The Exposed Pad should be connected to a strong ground plane for heat sinking and noise protection.
3. Keep the main current traces as possible as short and wide.
4. Vin will be connected with Vbattery with wide track, to avoid the interference of RF PA and Audio PA.

PACKAGE INFORMATION

DFN2x2-6L

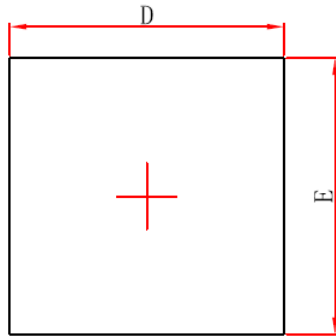

Top View

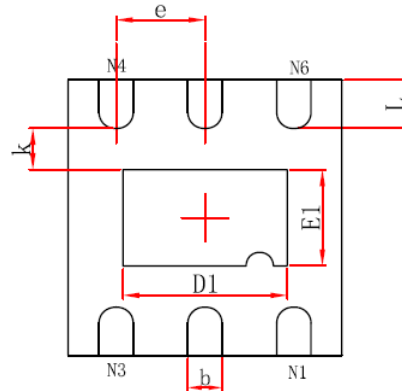

Bottom View

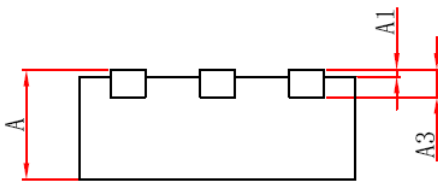

Side View

Symbol	Dimensions in Millimeters			Dimensions in Inches		
	Min.	Typ.	Max.	Min.	Typ.	Max.
A	0.7	0.75	0.8	0.028	0.0295	0.031
A1	0	0.025	0.05	0	0.001	0.002
A3	0.203REF.			0.008REF.		
D	1.924	2.0	2.076	0.076	0.079	0.082
E	1.924	2.0	2.076	0.076	0.079	0.082
D1	1.1	1.2	1.3	0.043	0.047	0.051
E1	0.6	0.7	0.8	0.024	0.027	0.031
k	0.2MIN.			0.008MIN.		
b	0.2	0.25	0.3	0.007	0.01	0.012
e	0.65TYP.			0.026TYP.		
L	0.274	0.35	0.426	0.011	0.014	0.017