P-Channel Enhancement-Mode Vertical DMOS FET

Features

- High Input Impedance and High Gain
- Low Power Drive Requirement
- Ease of Paralleling
- Low C_{ISS} and Fast Switching Speeds
- Excellent Thermal Stability
- Integral Source-Drain Diode
- Free from Secondary Breakdown

Applications

- Logic-Level Interfaces (Ideal for TTL and CMOS)
- Solid-State Relays
- Analog Switches
- Power Management
- Telecommunication Switches

General Description

The TP5335 is a low-threshold, Enhancement-mode (normally-off) transistor that utilizes an advanced vertical DMOS structure and a well-proven silicon gate manufacturing process. This combination produces a device with the power handling capabilities of bipolar transistors and the high input impedance and positive temperature coefficient inherent in MOS devices. Characteristic of all MOS structures, this device is free from thermal runaway and thermally induced secondary breakdown.

Microchip's vertical DMOS FETs are ideally suited to a wide range of switching and amplifying applications where high breakdown voltage, high input impedance, low input capacitance, and fast switching speeds are desired.

Package Type

3-lead SOT-23
(Top view)

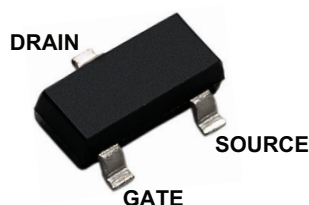

See [Table 2-1](#) for pin information.

TP5335

1.0 ELECTRICAL CHARACTERISTICS

Absolute Maximum Ratings†

Drain-to-Source Voltage	BV_{DSS}
Drain-to-Gate Voltage	BV_{DGS}
Gate-to-Source Voltage	$\pm 20V$
Junction Temperature, T_J	$-55^{\circ}C$ to $+150^{\circ}C$
Storage Temperature, T_S	$-55^{\circ}C$ to $+150^{\circ}C$

† **Notice:** Stresses above those listed under “Absolute Maximum Ratings” may cause permanent damage to the device. This is a stress rating only, and functional operation of the device at those or any other conditions above those indicated in the operational sections of this specification is not intended. Exposure to maximum rating conditions for extended periods may affect device reliability.

DC ELECTRICAL CHARACTERISTICS – COMMERCIAL

Electrical Specifications: $T_A = T_J = 25^{\circ}C$ unless otherwise specified. All DC parameters are 100% tested at $25^{\circ}C$ unless otherwise stated. (Pulse test: 300 μs pulse, 2% duty cycle.)

Parameter	Sym.	Min.	Typ.	Max.	Unit	Conditions
Drain-to-Source Breakdown Voltage	BV_{DSS}	-350	—	—	V	$V_{GS} = 0V, I_D = -100 \mu A$
Gate Threshold Voltage	$V_{GS(th)}$	-1	—	-2.4	V	$V_{DS} = V_{GS}, I_D = -1 mA$
Change in $V_{GS(th)}$ with Temperature	$\Delta V_{GS(th)}$	—	—	4.5	mV/ $^{\circ}C$	$V_{DS} = V_{GS}, I_D = -1 mA$ (Note 1)
Gate Body Leakage	I_{GSS}	—	—	-100	nA	$V_{GS} = \pm 20V, V_{DS} = 0V$
Zero-Gate Voltage Drain Current	I_{DSS}	—	—	-10	μA	$V_{DS} = \text{Maximum rating}, V_{GS} = 0V$
		—	—	-1	mA	$V_{DS} = \text{Maximum rating}, V_{GS} = 0V, T_A = 125^{\circ}C$ (Note 1)
On-State Drain Current	$I_{D(ON)}$	-200	—	—	mA	$V_{GS} = -4.5V, V_{DS} = -25V$
		-400	—	—	mA	$V_{GS} = -10V, V_{DS} = -25V$
Static Drain-to-Source On-State Resistance	$R_{DS(ON)}$	—	—	75	Ω	$V_{GS} = -4.5V, I_D = -150 mA$
		—	—	30	Ω	$V_{GS} = -10V, I_D = -200 mA$
Change in $R_{DS(ON)}$ with Temperature	$\Delta R_{DS(ON)}$	—	—	1.7	%/ $^{\circ}C$	$V_{GS} = -10V, I_D = -200 mA$ (Note 1)

Note 1: Specification is obtained by characterization and is not 100% tested.

DC ELECTRICAL CHARACTERISTICS – AUTOMOTIVE

Electrical Specifications: $T_A = T_J = (-55^{\circ}C, 25^{\circ}C, \text{ or } 150^{\circ}C)$ unless otherwise specified. All DC parameters are 100% tested at all three temperatures unless otherwise stated. (Pulse test: 300 μs pulse, 2% duty cycle.)

Parameter	Sym.	Min.	Typ.	Max.	Unit	Conditions
Drain-to-Source Breakdown Voltage	BV_{DSS}	-350	—	—	V	$V_{GS} = 0V, I_D = -100 \mu A$
Gate Threshold Voltage	$V_{GS(th)}$	-1	—	-2.4	V	$V_{DS} = V_{GS}, I_D = -1 mA$
Change in $V_{GS(th)}$ with Temperature	$\Delta V_{GS(th)}$	—	3.3	—	mV/ $^{\circ}C$	$V_{DS} = V_{GS}, I_D = -1 mA$ (Note 1)
Gate Body Leakage	I_{GSS}	—	—	-100	nA	$V_{GS} = \pm 20V, V_{DS} = 0V$
		—	—	-220	nA	$V_{GS} = \pm 20V, V_{DS} = 0V, T_A = 150^{\circ}C$

Note 1: Specification is obtained by characterization and is not 100% tested.

DC ELECTRICAL CHARACTERISTICS – AUTOMOTIVE (CONTINUED)

Electrical Specifications: $T_A = T_J = (-55^{\circ}\text{C}, 25^{\circ}\text{C}, \text{ or } 150^{\circ}\text{C})$ unless otherwise specified. All DC parameters are 100% tested at all three temperatures unless otherwise stated. (Pulse test: 300 μs pulse, 2% duty cycle.)

Parameter	Sym.	Min.	Typ.	Max.	Unit	Conditions
Zero-Gate Voltage Drain Current	I_{DSS}	—	—	-10	μA	$V_{DS} = \text{Maximum rating}, V_{GS} = 0\text{V}$
		—	—	-1	mA	$V_{DS} = \text{Maximum rating}, V_{GS} = 0\text{V}, T_A = 150^{\circ}\text{C}$
On-State Drain Current	$I_{D(ON)}$	-200	—	—	mA	$V_{GS} = -4.5\text{V}, V_{DS} = -25\text{V}$
		-400	—	—	mA	$V_{GS} = -10\text{V}, V_{DS} = -25\text{V}$
		-375	—	—	mA	$V_{GS} = -10\text{V}, V_{DS} = -25\text{V}, T_A = 150^{\circ}\text{C}$
Static Drain-to-Source On-State Resistance	$R_{DS(ON)}$	—	—	75	Ω	$V_{GS} = -4.5\text{V}, I_D = -150\text{mA}$
		—	—	30	Ω	$V_{GS} = -10\text{V}, I_D = -200\text{mA}$
		—	—	70	Ω	$V_{GS} = -10\text{V}, I_D = -200\text{mA}, T_A = 150^{\circ}\text{C}$
Change in $R_{DS(ON)}$ with Temperature	$\Delta R_{DS(ON)}$	—	1	—	$\%/^{\circ}\text{C}$	$V_{GS} = -10\text{V}, I_D = -200\text{mA}$ (Note 1)

Note 1: Specification is obtained by characterization and is not 100% tested.

AC ELECTRICAL CHARACTERISTICS – COMMERCIAL

Electrical Specifications: $T_A = T_J = 25^{\circ}\text{C}$ unless otherwise specified. Specification is obtained by characterization and is not 100% tested.

Parameter	Sym.	Min.	Typ.	Max.	Unit	Conditions
Forward Transconductance	G_{FS}	125	—	—	mmho	$V_{DS} = -25\text{V}, I_D = -200\text{mA}$
Input Capacitance	C_{ISS}	—	—	110	pF	$V_{GS} = 0\text{V}, V_{DS} = -25\text{V}, f = 1\text{MHz}$
Common Source Output Capacitance	C_{OSS}	—	—	60	pF	
Reverse Transfer Capacitance	C_{RSS}	—	—	22	pF	
Turn-On Delay Time	$t_{d(ON)}$	—	—	20	ns	$V_{DD} = -25\text{V}, I_D = -150\text{mA}, R_{GEN} = 25\Omega$
Rise Time	t_r	—	—	15	ns	
Turn-Off Delay Time	$t_{d(OFF)}$	—	—	25	ns	
Fall Time	t_f	—	—	25	ns	
DIODE PARAMETER						
Diode Forward Voltage Drop	V_{SD}	—	—	-1.8	V	$V_{GS} = 0\text{V}, I_{SD} = -200\text{mA}$ (Note 1)
Reverse Recovery Time	t_{rr}	—	800	—	ns	$V_{GS} = 0\text{V}, I_{SD} = -200\text{mA}$

Note 1: All DC parameters are 100% tested at 25°C unless otherwise stated. (Pulse test: 300 μs pulse, 2% duty cycle.)

TP5335

AC ELECTRICAL CHARACTERISTICS – AUTOMOTIVE

Electrical Specifications: $T_A = T_J = 25^\circ\text{C}$ unless otherwise specified. Specification is obtained by characterization and is not 100% tested.

Parameter	Sym.	Min.	Typ.	Max.	Unit	Conditions
Forward Transconductance	G_{FS}	—	285	—	mmho	$V_{DS} = -25\text{V}, I_D = -200\text{ mA}$
Input Capacitance	C_{ISS}	—	80	—	pF	$V_{GS} = 0\text{V}, V_{DS} = -25\text{V},$ $f = 1\text{ MHz}$
Common Source Output Capacitance	C_{OSS}	—	12	—	pF	
Reverse Transfer Capacitance	C_{RSS}	—	2	—	pF	
Turn-On Delay Time	$t_{d(ON)}$	—	7.6	—	ns	$V_{DD} = -25\text{V}, I_D = -150\text{ mA},$ $R_{GEN} = 25\Omega$
Rise Time	t_r	—	3	—	ns	
Turn-Off Delay Time	$t_{d(OFF)}$	—	19	—	ns	
Fall Time	t_f	—	10	—	ns	
DIODE PARAMETER						
Diode Forward Voltage Drop	V_{SD}	—	—	-1.8	V	$V_{GS} = 0\text{V}, I_{SD} = -200\text{ mA}$ (Note 1)
Reverse Recovery Time	t_{rr}	—	450	—	ns	$V_{GS} = 0\text{V}, I_{SD} = -200\text{ mA}$

Note 1: 100% Production Tested at $T_A = T_J = (-55^\circ\text{C}, 25^\circ\text{C}, \text{ and } 150^\circ\text{C})$.

TEMPERATURE SPECIFICATIONS

Parameter	Sym.	Min.	Typ.	Max.	Unit	Conditions
TEMPERATURE RANGE						
Operating Junction Temperature	T_J	-55	—	+150	$^\circ\text{C}$	
Storage Temperature	T_S	-55	—	+150	$^\circ\text{C}$	
PACKAGE THERMAL RESISTANCE						
3-lead SOT-23	θ_{JA}	—	203	—	$^\circ\text{C/W}$	

THERMAL CHARACTERISTICS

Package	I_D (Note 1) (Continuous) (mA)	I_D (Pulsed) (mA)	Power Dissipation at $T_A = 25^\circ\text{C}$ (W)	I_{DR} (Note 1) (mA)	I_{DRM} (mA)
3-lead SOT-23	-85	-400	0.36	-85	-400

Note 1: I_D (continuous) is limited by maximum T_J .

2.0 PIN DESCRIPTION

Table 2-1 shows the description of pins in TP5335 SOT-23. Refer to [Package Type](#) for the location of pins.

TABLE 2-1: PIN FUNCTION TABLE

Pin Number	Pin Name	Description
1	Gate	Gate
2	Source	Source
3	Drain	Drain

TP5335

3.0 FUNCTIONAL DESCRIPTION

Figure 3-1 illustrates the switching waveforms and test circuit for TP5335.

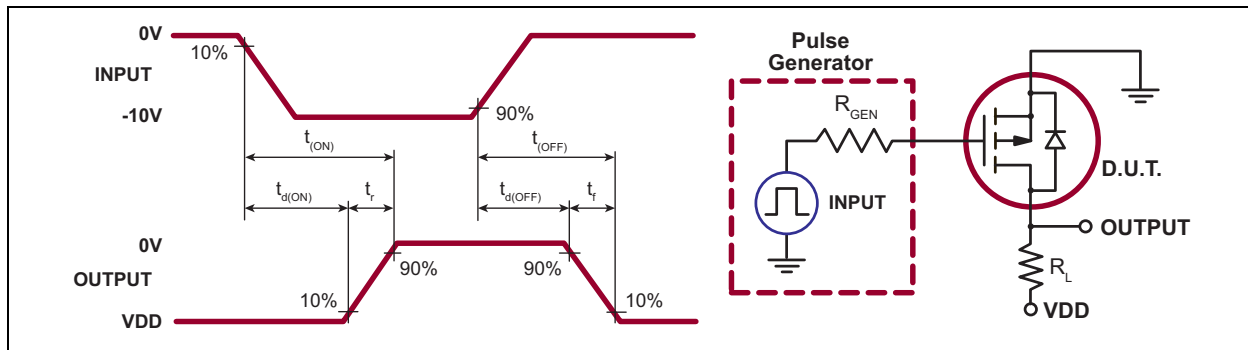

FIGURE 3-1: Switching Waveforms and Test Circuit.

TABLE 3-1: PRODUCT SUMMARY

BV_{DSS}/BV_{DGS} (V)	$R_{DS(ON)}$ (Maximum) (Ω)	$V_{GS(th)}$ (Maximum) (V)
-350	30	-2.4

4.0 PACKAGING INFORMATION

4.1 Package Marking Information

3-lead SOT-23

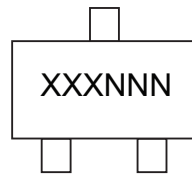

Example

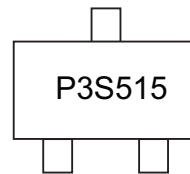

Legend:	XX...X	Product Code or Customer-specific information
	Y	Year code (last digit of calendar year)
	YY	Year code (last 2 digits of calendar year)
	WW	Week code (week of January 1 is week '01')
	NNN	Alphanumeric traceability code
	(e3)	Pb-free JEDEC [®] designator for Matte Tin (Sn)
	*	This package is Pb-free. The Pb-free JEDEC designator (e3) can be found on the outer packaging for this package.
Note:	In the event the full Microchip part number cannot be marked on one line, it will be carried over to the next line, thus limiting the number of available characters for product code or customer-specific information. Package may or not include the corporate logo.	

3-Lead TO-236AB (SOT-23) Package Outline (K1/T) 2.90x1.30mm body, 1.12mm height (max), 1.90mm pitch

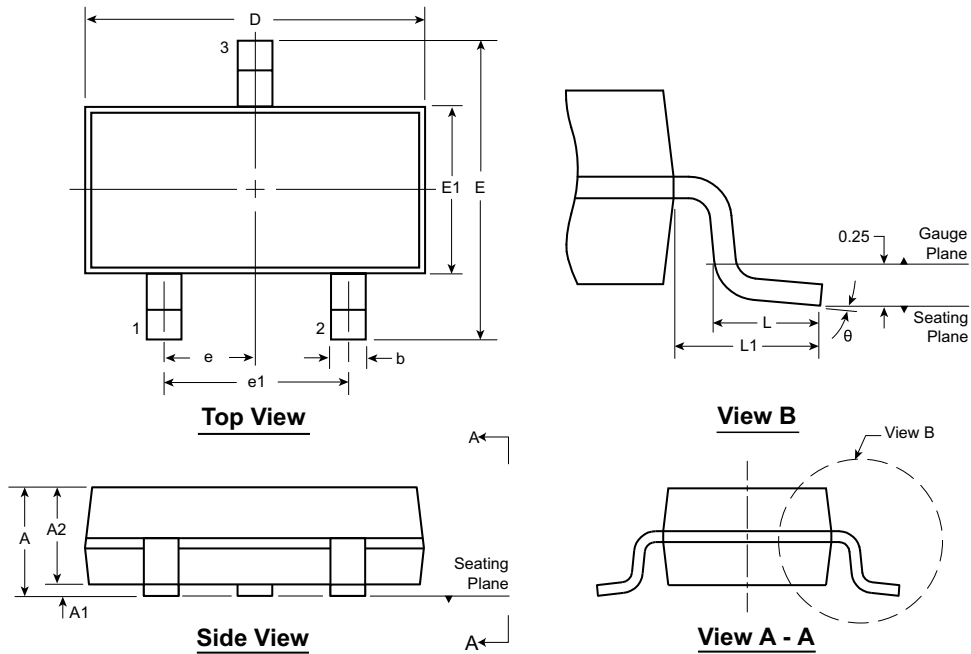

Note: For the most current package drawings, see the Microchip Packaging Specification at www.microchip.com/packaging.

Symbol		A	A1	A2	b	D	E	E1	e	e1	L	L1	θ
Dimension (mm)	MIN	0.89	0.01	0.88	0.30	2.80	2.10	1.20	0.95 BSC	1.90 BSC	0.20 [†]	0.54 REF	0°
	NOM	-	-	0.95	-	2.90	-	1.30			0.50		-
	MAX	1.12	0.10	1.02	0.50	3.04	2.64	1.40			0.60		8°

JEDEC Registration TO-236, Variation AB, Issue H, Jan. 1999.

[†] This dimension differs from the JEDEC drawing.

Drawings not to scale.

APPENDIX A: REVISION HISTORY

Revision A (December 2018)

- Converted Supertex Doc# DSFP-TP5335 to Microchip DS20005704A
- Made minor text changes throughout the document

Revision B (February 2020)

- Revised the order of pins in the Pin Function Table
- Revised the Electrical Specifications and included notes in the DC Electrical Characteristics and AC Electrical Characteristics tables
- Made minor text changes throughout the document

Revision C (June 2020)

- Added automotive specifications to the Electrical Characteristics section
- Added automotive specifications to the Product Identification System section
- Made minor text changes throughout the document

TP5335

PRODUCT IDENTIFICATION SYSTEM

To order or obtain information, e.g., on pricing or delivery, contact your local Microchip representative or sales office.

<u>PART NO.</u>					
Device	XX Package Options	-	X Environmental	-	X Media Type Option
Device:	TP5335	=	P-Channel Enhancement-Mode Vertical DMOS FET		
Package:	K1	=	3-lead SOT-23		
Environmental:	G	=	Lead (Pb)-free/RoHS-compliant Package		
Media Type:	(blank)	=	3000/Reel for a K1 Package		
Option:	VAO	=	Automotive Grade		

Example:

- a) TP5335K1-G: P-Channel Enhancement-Mode Vertical DMOS FET, 3-lead SOT-23, 3000/Reel
- b) TP5335K1-G-VAO: P-Channel Enhancement-Mode Vertical DMOS FET, Automotive Grade, 3-lead SOT-23, 3000/Reel

Note the following details of the code protection feature on Microchip devices:

- Microchip products meet the specification contained in their particular Microchip Data Sheet.
- Microchip believes that its family of products is one of the most secure families of its kind on the market today, when used in the intended manner and under normal conditions.
- There are dishonest and possibly illegal methods used to breach the code protection feature. All of these methods, to our knowledge, require using the Microchip products in a manner outside the operating specifications contained in Microchip's Data Sheets. Most likely, the person doing so is engaged in theft of intellectual property.
- Microchip is willing to work with the customer who is concerned about the integrity of their code.
- Neither Microchip nor any other semiconductor manufacturer can guarantee the security of their code. Code protection does not mean that we are guaranteeing the product as “unbreakable.”

Code protection is constantly evolving. We at Microchip are committed to continuously improving the code protection features of our products. Attempts to break Microchip's code protection feature may be a violation of the Digital Millennium Copyright Act. If such acts allow unauthorized access to your software or other copyrighted work, you may have a right to sue for relief under that Act.

Information contained in this publication regarding device applications and the like is provided only for your convenience and may be superseded by updates. It is your responsibility to ensure that your application meets with your specifications. MICROCHIP MAKES NO REPRESENTATIONS OR WARRANTIES OF ANY KIND WHETHER EXPRESS OR IMPLIED, WRITTEN OR ORAL, STATUTORY OR OTHERWISE, RELATED TO THE INFORMATION, INCLUDING BUT NOT LIMITED TO ITS CONDITION, QUALITY, PERFORMANCE, MERCHANTABILITY OR FITNESS FOR PURPOSE. Microchip disclaims all liability arising from this information and its use. Use of Microchip devices in life support and/or safety applications is entirely at the buyer's risk, and the buyer agrees to defend, indemnify and hold harmless Microchip from any and all damages, claims, suits, or expenses resulting from such use. No licenses are conveyed, implicitly or otherwise, under any Microchip intellectual property rights unless otherwise stated.

Trademarks

The Microchip name and logo, the Microchip logo, Adaptec, AnyRate, AVR, AVR logo, AVR Freaks, BesTime, BitCloud, chipKIT, chipKIT logo, CryptoMemory, CryptoRF, dsPIC, FlashFlex, flexPWR, HELDO, IGLoo, JukeBlox, KeeLoq, Klear, LANCheck, LinkMD, maXStylus, maXTouch, MediaLB, megaAVR, Microsemi, Microsemi logo, MOST, MOST logo, MPLAB, OptoLyzer, PackeTime, PIC, picoPower, PICSTART, PIC32 logo, PolarFire, Prochip Designer, QTouch, SAM-BA, SenGenuity, SpyNIC, SST, SST Logo, SuperFlash, Symmetricom, SyncServer, Tachyon, TempTrackr, TimeSource, tinyAVR, UNI/O, Vectron, and XMEGA are registered trademarks of Microchip Technology Incorporated in the U.S.A. and other countries.

APT, ClockWorks, The Embedded Control Solutions Company, EtherSynch, FlashTec, Hyper Speed Control, HyperLight Load, IntelliMOS, Libero, motorBench, mTouch, Powermite 3, Precision Edge, ProASIC, ProASIC Plus, ProASIC Plus logo, Quiet-Wire, SmartFusion, SyncWorld, Temux, TimeCesium, TimeHub, TimePictra, TimeProvider, Vite, WinPath, and ZL are registered trademarks of Microchip Technology Incorporated in the U.S.A.

Adjacent Key Suppression, AKS, Analog-for-the-Digital Age, Any Capacitor, AnyIn, AnyOut, BlueSky, BodyCom, CodeGuard, CryptoAuthentication, CryptoAutomotive, CryptoCompanion, CryptoController, dsPICDEM, dsPICDEM.net, Dynamic Average Matching, DAM, ECAN, EtherGREEN, In-Circuit Serial Programming, ICSP, INICnet, Inter-Chip Connectivity, JitterBlocker, KlearNet, KlearNet logo, memBrain, Mindi, MiWi, MPASM, MPF, MPLAB Certified logo, MPLIB, MPLINK, MultiTRAK, NetDetach, Omniscient Code Generation, PICDEM, PICDEM.net, PICKit, PICtail, PowerSmart, PureSilicon, QMatrix, REAL ICE, Ripple Blocker, SAM-ICE, Serial Quad I/O, SMART-I.S., SQR, SuperSwitcher, SuperSwitcher II, Total Endurance, TSHARC, USBCheck, VariSense, ViewSpan, WiperLock, Wireless DNA, and ZENA are trademarks of Microchip Technology Incorporated in the U.S.A. and other countries.

SQTP is a service mark of Microchip Technology Incorporated in the U.S.A.

The Adaptec logo, Frequency on Demand, Silicon Storage Technology, and Symmcom are registered trademarks of Microchip Technology Inc. in other countries.

GestIC is a registered trademark of Microchip Technology Germany II GmbH & Co. KG, a subsidiary of Microchip Technology Inc., in other countries.

All other trademarks mentioned herein are property of their respective companies.

© 2018-2020, Microchip Technology Incorporated, All Rights Reserved.

ISBN: 978-1-5224-6243-9

For information regarding Microchip's Quality Management Systems, please visit www.microchip.com/quality.



MICROCHIP

Worldwide Sales and Service

AMERICAS

Corporate Office

2355 West Chandler Blvd.
Chandler, AZ 85224-6199

Tel: 480-792-7200

Fax: 480-792-7277

Technical Support:

[http://www.microchip.com/
support](http://www.microchip.com/support)

Web Address:

www.microchip.com

Atlanta

Duluth, GA

Tel: 678-957-9614

Fax: 678-957-1455

Austin, TX

Tel: 512-257-3370

Boston

Westborough, MA

Tel: 774-760-0087

Fax: 774-760-0088

Chicago

Itasca, IL

Tel: 630-285-0071

Fax: 630-285-0075

Dallas

Addison, TX

Tel: 972-818-7423

Fax: 972-818-2924

Detroit

Novi, MI

Tel: 248-848-4000

Houston, TX

Tel: 281-894-5983

Indianapolis

Noblesville, IN

Tel: 317-773-8323

Fax: 317-773-5453

Tel: 317-536-2380

Los Angeles

Mission Viejo, CA

Tel: 949-462-9523

Fax: 949-462-9608

Tel: 951-273-7800

Raleigh, NC

Tel: 919-844-7510

New York, NY

Tel: 631-435-6000

San Jose, CA

Tel: 408-735-9110

Tel: 408-436-4270

Canada - Toronto

Tel: 905-695-1980

Fax: 905-695-2078

ASIA/PACIFIC

Australia - Sydney

Tel: 61-2-9868-6733

China - Beijing

Tel: 86-10-8569-7000

China - Chengdu

Tel: 86-28-8665-5511

China - Chongqing

Tel: 86-23-8980-9588

China - Dongguan

Tel: 86-769-8702-9880

China - Guangzhou

Tel: 86-20-8755-8029

China - Hangzhou

Tel: 86-571-8792-8115

China - Hong Kong SAR

Tel: 852-2943-5100

China - Nanjing

Tel: 86-25-8473-2460

China - Qingdao

Tel: 86-532-8502-7355

China - Shanghai

Tel: 86-21-3326-8000

China - Shenyang

Tel: 86-24-2334-2829

China - Shenzhen

Tel: 86-755-8864-2200

China - Suzhou

Tel: 86-186-6233-1526

China - Wuhan

Tel: 86-27-5980-5300

China - Xian

Tel: 86-29-8833-7252

China - Xiamen

Tel: 86-592-2388138

China - Zhuhai

Tel: 86-756-3210040

ASIA/PACIFIC

India - Bangalore

Tel: 91-80-3090-4444

India - New Delhi

Tel: 91-11-4160-8631

India - Pune

Tel: 91-20-4121-0141

Japan - Osaka

Tel: 81-6-6152-7160

Japan - Tokyo

Tel: 81-3-6880-3770

Korea - Daegu

Tel: 82-53-744-4301

Korea - Seoul

Tel: 82-2-554-7200

Malaysia - Kuala Lumpur

Tel: 60-3-7651-7906

Malaysia - Penang

Tel: 60-4-227-8870

Philippines - Manila

Tel: 63-2-634-9065

Singapore

Tel: 65-6334-8870

Taiwan - Hsin Chu

Tel: 886-3-577-8366

Taiwan - Kaohsiung

Tel: 886-7-213-7830

Taiwan - Taipei

Tel: 886-2-2508-8600

Thailand - Bangkok

Tel: 66-2-694-1351

Vietnam - Ho Chi Minh

Tel: 84-28-5448-2100

EUROPE

Austria - Wels

Tel: 43-7242-2244-39

Fax: 43-7242-2244-393

Denmark - Copenhagen

Tel: 45-4485-5910

Fax: 45-4485-2829

Finland - Espoo

Tel: 358-9-4520-820

France - Paris

Tel: 33-1-69-53-63-20

Fax: 33-1-69-30-90-79

Germany - Garching

Tel: 49-8931-9700

Germany - Haan

Tel: 49-2129-3766400

Germany - Heilbronn

Tel: 49-7131-72400

Germany - Karlsruhe

Tel: 49-721-625370

Germany - Munich

Tel: 49-89-627-144-0

Fax: 49-89-627-144-44

Germany - Rosenheim

Tel: 49-8031-354-560

Israel - Ra'anana

Tel: 972-9-744-7705

Italy - Milan

Tel: 39-0331-742611

Fax: 39-0331-466781

Italy - Padova

Tel: 39-049-7625286

Netherlands - Drunen

Tel: 31-416-690399

Fax: 31-416-690340

Norway - Trondheim

Tel: 47-7288-4388

Poland - Warsaw

Tel: 48-22-3325737

Romania - Bucharest

Tel: 40-21-407-87-50

Spain - Madrid

Tel: 34-91-708-08-90

Fax: 34-91-708-08-91

Sweden - Gothenberg

Tel: 46-31-704-60-40

Sweden - Stockholm

Tel: 46-8-5090-4654

UK - Wokingham

Tel: 44-118-921-5800

Fax: 44-118-921-5820