

REV.	ECN.	NO.	APPD.
X1	02/06'17		Davy Bu
X2	03/10'17		Davy Bu
X3	11/21'18		Davy Bu
X4	03/31'20		Davy Bu

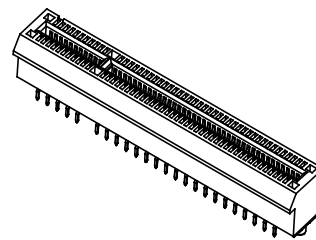

NOTES:

- ELECTRICAL CHARACTERISTICS:
 - 1-1 CURRENT RATING: 1.1 A MAX. PER PIN, 30°C RISE ABOVE AMBIENT.
 - 1-2 CONTACT RESISTANCE: 30 MILLIOHMS MAX. INITIAL, NO CHANGE GREATER THAN 20 MILLIOHMS AFTER TEST.
 - 1-3 INSULATION RESISTANCE: 1000 MEGOHMS MIN.
 - 1-4 DIELECTRICAL WITHSTAND VOLTAGE: 500 V AC MIN. AT SEA LEVEL.
- MECHANICAL CHARACTERISTICS:
 - 2-1 CONTACT INSERTION FORCE: 1.15 N MAX. PER CONTACT PAIR.
 - 2-2 CONTACT REMOVAL FORCE: 0.15 N MIN. PER CONTACT PAIR.
 - 2-3 DURABILITY: 50 MATING AND UNMATING CYCLES.
 - 2-4 CONTACT RETENTION FORCE: 4.9 N MIN.
- ENVIRONMENTAL CHARACTERISTICS:
 - 3-1 OPERATING TEMPERATURE RANGE: -40°C TO +105°C.
- PLEASE CONTACT FOXCONN SALES REPRESENTATIVE TO VERIFY PRODUCTION DETAILS & AVAILABILITY
- RECOMMENDED PROCESS CONDITION: WAVE SOLDER, 260°C, 3~5 S.

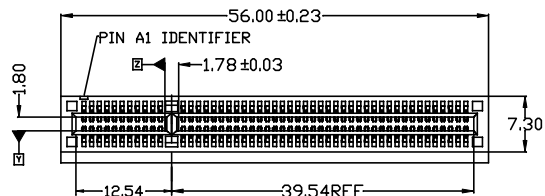
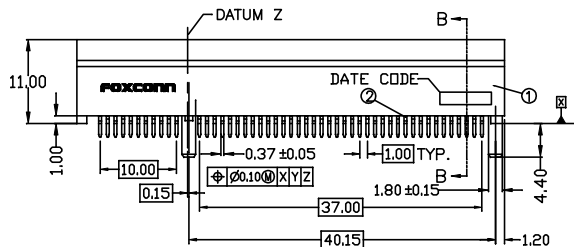
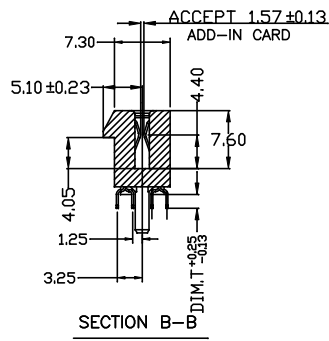

PROD. NO.: 2EG 0 49 * * - DP*0- 4F

FIELD PRODUCT SERIES: 2EG= PCI EXPRESS

TERMINAL TYPE: 0= VERTICAL TYPE

NO. OF POS. 49= 98 POSITIONS

PLATING TYPE:
4F= SOFT TRAY & LEAD FREE

EXTENSION CODE
D= BLACK
L= BLUE
W= WHITE

CONTACT AREA GOLD PLATING:
1= GOLD FLASH
7= 15u" GOLD
3= 30u" GOLD

TAIL LENGTH:
1= 2.30mm
2= 3.10mm
3= 3.56mm
4= 2.54mm

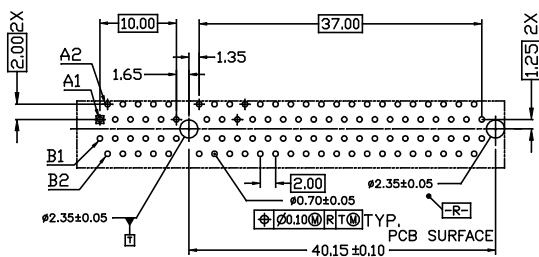

RECOMMENDED PCB LAYOUT

2EG0494*-DP*0-4F	2.54
2EG0493*-DP*0-4F	3.56
2EG0492*-DP*0-4F	3.10
2EG0491*-DP*0-4F	2.30
PRODUCT NUMBER	DIM. T

ITEM	DESCRIPTION	MATERIAL	TREATMENT
2	CONTACT	COPPER ALLOY	50u" MIN. NICKEL PLATING OVERALL UNDERPLATED. 100u" MIN. MATTE TIN PLATING OVER NICKEL AT TAIL. GOLD PLATING ON CONTACT AREA.
1	HOUSING	HIGH TEMPERATURE THERMOPLASTIC UL V-0	MOLDED BLACK/BLUE

UNITS	mm	NAME (INTENDED USE)	FOXCONN INTERCONNECT TECHNOLOGY LIMITED.
X. ±	X. ±	Vertical, T/H	
.X ± 0.38	.X ±	PART NO. (INTENDED USE)	CLASS: <input type="checkbox"/> CONFIDENTIAL <input type="checkbox"/> SECRET <input checked="" type="checkbox"/> GENERAL
.XX ± 0.25	.XX ±	2EG049** - DP*0-4F	TITLE: PCI EXPRESS CUSTOMER DRAWING
.XXX ±	.XXX ±	APPD: Davy Bu 3/31'20	DWG NO.: 303-0000-****
THESE DRAWINGS AND SPECIFICATIONS ARE THE PROPERTY OF FOXCONN INTERCONNECT TECHNOLOGY LIMITED AND SHALL NOT BE REPRODUCED, COPIED OR USED IN ANY MANNER WITHOUT THE PRIOR WRITTEN CONSENT OF FOXCONN INTERCONNECT TECHNOLOGY LIMITED.		Q'TY N/A	CHKD: Johnny Tang 3/31'20
			DR: Hong Chen 3/31'20

SCALE	SHEET	REV.
N/A	1/3	X4

REV.	ECN.	NO.	APPD.
------	------	-----	-------

SEE SHEET 1/3

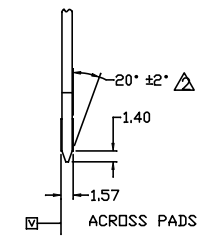
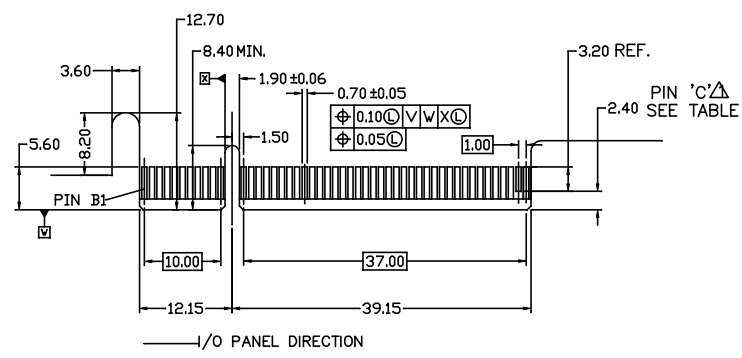

PRIMARY (COMPONENT) SIDE

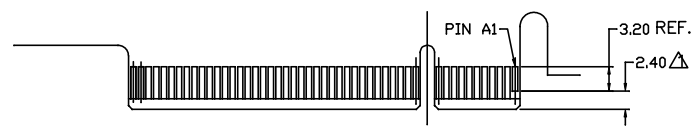

SECONDARY (SOLDER) SIDE

ADD-IN CARD EDGE-FINGER DIMENSIONS

2EG049**--DP*0-4F	98/BX	B48
PART NUMBER	NO. PDS /WAY	c 1

NOTES:

- △ NO TIE PERMITTED FROM CARD EDGE TO LEADING EDGE OF PAD FOR PINS A1 AND 'C'.
- △ CHAMFER EDGES MUST BE FREE OF CUTTING BURRS.

X. ±	X°. ±	UNITS	mm	NAME (INTENDED USE)	 FOXCONN INTERCONNECT TECHNOLOGY LIMITED.			
.X ± 0.25	.X° ±	MAT'L	N/A	Vertical, T/H				
.XX ± 0.13	.XX° ±	FINISH	N/A	PART NO. (INTENDED USE)	CLASS: <input type="checkbox"/> CONFIDENTIAL <input type="checkbox"/> SECRET <input checked="" type="checkbox"/> GENERAL			
.XXX ±	.XXX° ±		APPD:	Davy Bu 3/31'20	2EG049**--DP*0-4F	TITLE: PCI EXPRESS CUSTOMER DRAWING		
THESE DRAWINGS AND SPECIFICATIONS ARE THE PROPERTY OF FOXCONN INTERCONNECT TECHNOLOGY LIMITED AND SHALL NOT BE REPRODUCED, COPIED OR USED IN ANY MANNER WITHOUT THE PRIOR WRITTEN CONSENT OF FOXCONN INTERCONNECT TECHNOLOGY LIMITED.				Q'TY	N/A	DRG NO.:	303-0000-****	
				CHKD:	Johnny Tang 3/31'20	SCALE	SHEET	REV.
				DR:	Hong Chen 3/31'20	N/A	2/3	X4

REV.	ECN.	NO.	APPD.
------	------	-----	-------

SEE SHEET 1/3

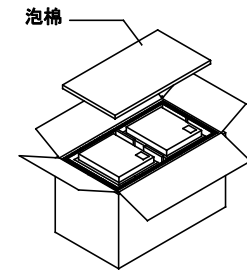
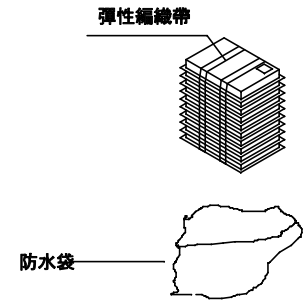

包裝過程

- (1) 如DWG-1所示, 將產品放入盤內;
 - (2) 紙箱中產品一疊, 共12盤, 最上面加放1PCS空盤, 相鄰兩盤以旋轉180°放置, 如圖二所示, 每疊以2PCS彈性編織帶紮緊
 - (3) 將疊好的產品裝入HDPE防水袋中
 - (4) 紙箱內底放入舒服多1PCS
側面放入舒服多2PCS
另兩側面放入舒服多2PCS
上面防水袋外再放舒服多1PCS
 - (5) 內標籤貼於最上面空包盤正中間
 - (6) 以TAPE成“H”型封箱後, 在外箱標記中貼標示單一張
- * 成品出貨時, 每箱實重應以實測重量為準
* 若需空運出貨, 則需照DWG-4用打包帶打包
* 若成品不足一箱, 倉庫出貨時應以空盒填滿整箱

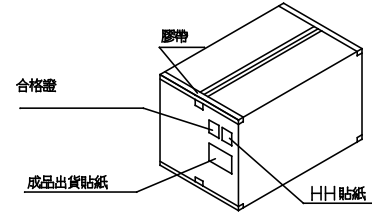
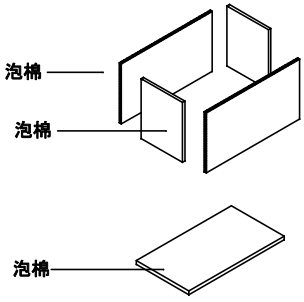
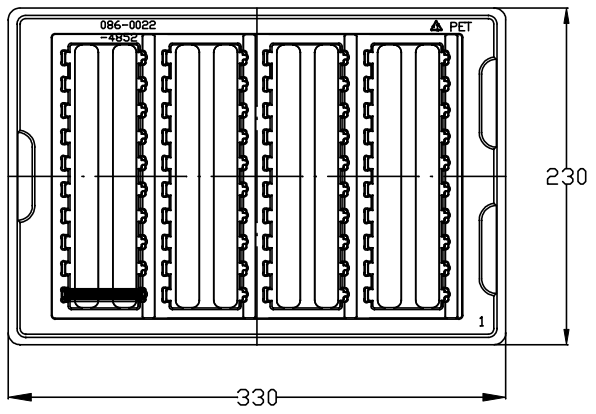

DRAW-3

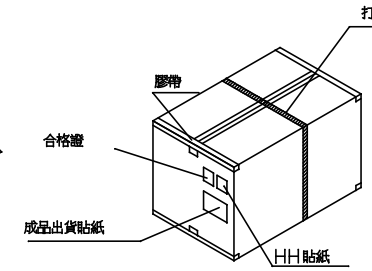
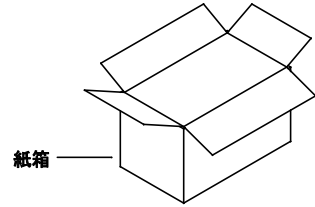

DRAW-4

DRAW-2

X.±	X°.±	UNITS	mm	NAME (INTENDED USE)	FOXCONN INTERCONNECT TECHNOLOGY LIMITED.
.X± 0.25	.X°.±	MAT'L	N/A	Vertical, T/H	
.XX± 0.13	.XX°.±			PART NO. (INTENDED USE)	CLASS: <input type="checkbox"/> CONFIDENTIAL <input type="checkbox"/> SECRET <input checked="" type="checkbox"/> GENERAL
.XXX±	.XXX°.±	FINISH	N/A	2EGO49**--DP*0-4F	TITLE: PCI EXPRESS CUSTOMER DRAWING
THESE DRAWINGS AND SPECIFICATIONS ARE THE PROPERTY OF FOXCONN INTERCONNECT TECHNOLOGY LIMITED AND SHALL NOT BE REPRODUCED, COPIED OR USED IN ANY MANNER WITHOUT THE PRIOR WRITTEN CONSENT OF FOXCONN INTERCONNECT TECHNOLOGY LIMITED.				APPD:	Davy Bu 3/31'20
				Q'TY	N/A
				DR:	Hong Chen 3/31'20
				SCALE	N/A
				SHEET	3/3
				REV.	X4

