

CFPA

Surface Mount Pushbutton Switches

Washable

RoHS Compliant

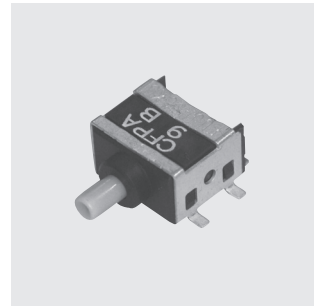

Features

1. Compatible with Reflow Soldering
2. Washable
3. Gold-Plated Contacts for Low Current Application
4. Clip Contact Mechanism for High Contact Reliability

Specifications

Rating	Max.	0.4VA (28VDC max.) (Resistive load)
	Min.	1 μ A 20mVDC (Resistive load)
Initial contact resistance	80m Ω max. (1.5mA 1kHz 20mV min.)	
Dielectric strength	500VAC 1 minute	
Initial insulation resistance	500M Ω min. (500VDC)	
Stroke	1.1 mm	
Operating force	1.5N \pm 1N	
Electrical life	50,000 operations at max. rating	
Switch timing	Non-shorting	
Operating temperature range	-40 $^{\circ}$ C ~ +85 $^{\circ}$ C	
Storage temperature range	-40 $^{\circ}$ C ~ +85 $^{\circ}$ C	

Part Numbering

CFPA - **1** **F** **B4** - **A** **2** **T**

Series code & Acuator

Code	Type
P	Pushbutton

Number of poles

Fig.	Number of poles
1	1 pole

Switching function

Code	Switching function
F	ON - (ON)

Terminal style

Fig.	Terminal style
B4	Gull wing R/A

Actuator shape

Code	Actuator shape
A	Standard

Contact material

Fig.	Contact material
2	Gold plated

Packaging specifications

Code	Packaging specifications
T	Taping
W	Tray

Optional Accessories

《Sold separately》

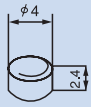

Part Name	Dimensions	Color	Part Number
Color Cap	Gloss finish  ABS resin	White	140000481453
		Red	140000481452
		Black	140000481451
		Gray	140000481450

The color cap should be installed after the reflow soldering and washing process.

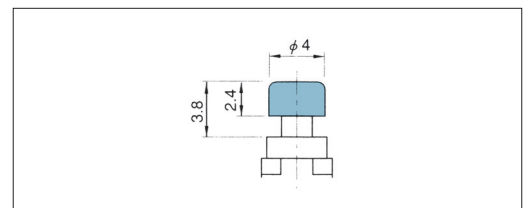
Color Cap Mounting



Switching function

	Switching function		
Part No.		ON	(ON)
CFPA-1FB4-A2		ON	(ON)
Connecting terminals		2-3	2-1

■ : Packing specifications T or W (ON) : Momentary

Pad Layouts

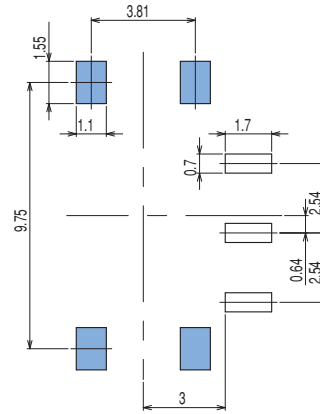

Dimension

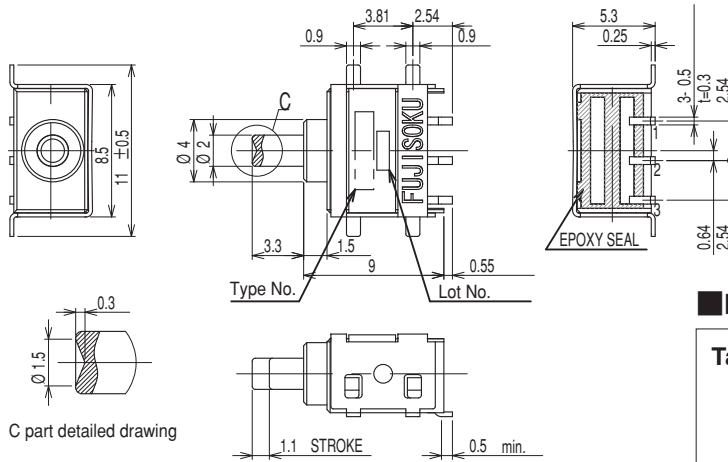

C part detailed drawing

Table of Part Numbers

Packaging specifications	Part No.
Taping	CFPA-1FB4-A2T
Tray	CFPA-1FB4-A2W

Soldering Specifications

(1) Reflow Soldering

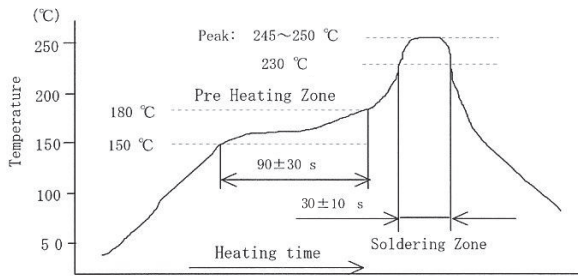

Apply reflow soldering: 2 times max.

(2) Manual Soldering

Device : Soldering iron
Max.: 3-4 seconds. Max.

Flux Cleaning

- (1) For the solvent, use water or alcohol. In addition, pay careful attention to use the solvent.
- (2) The cleaning method is limited to immersion cleaning only. The cleaning time is 2 minutes, max, but be sure to minimize the time as much as possible.
- (3) To clean the switch after soldering, wait until the switch temperature has cooled down to room temperature (30°C or below).
- (4) The product must be dried sufficiently after cleaning. Improper drying may result in fluctuation in torque or electrical damage.

Packaging Specifications

Taping

500 pcs/reel

Tray

50 pcs/tray