

CMSN1012H3-HF

N-Channel
RoHS Device
Halogen Free

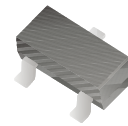

BV_{DSS}	20V
I_D	560mA
R_{DS(on)} @V_{GS} =4.5V, I_D =600mA	320mΩ (typ)
R_{DS(on)} @V_{GS} =2.5V, I_D =400mA	510mΩ (typ)
R_{DS(on)} @V_{GS} =1.8V, I_D =350mA	980mΩ (typ)

Features

- Simple drive requirement
- Small package outline
- Pb-free lead plating and halogen-free package

Circuit Diagram

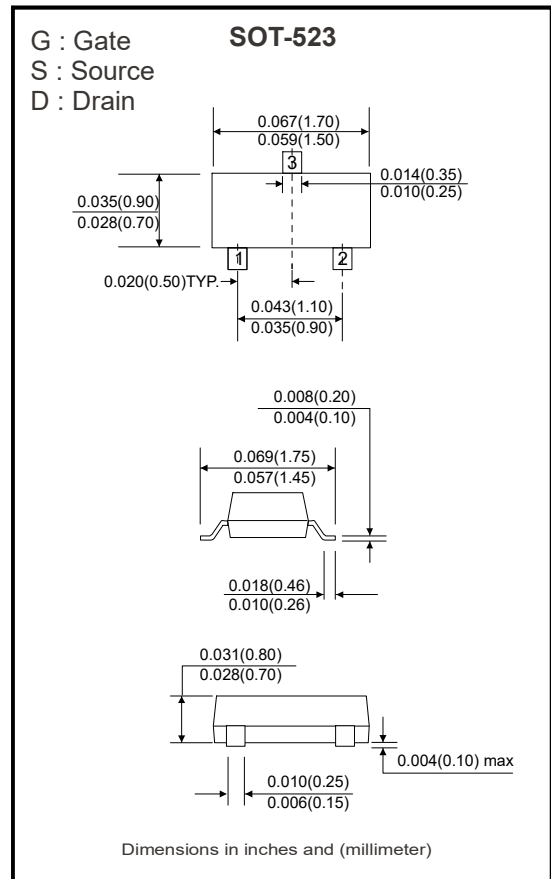
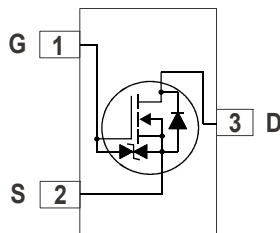

Maximum Rating (at Ta=25°C unless otherwise noted)

Parameter	Symbol	Limits	Unit	
Drain-Source Voltage	V _{DS}	20	V	
Gate-Source Voltage	V _{GS}	±8		
Continuous Drain Current @ T _A =25 °C, V _{GS} =4.5V(Note 3)	I _D	560	mA	
Continuous Drain Current @ T _A =85 °C, V _{GS} =4.5V(Note 3)		400		
Pulsed Drain Current(Notes 1, 2)	I _{DM}	2.5	A	
Maximum Power Dissipation (Note 3)	P _D	T _A =25 °C	150	mW
		T _A =85 °C	80	
ESD susceptibility		2000 (Note 4)	V	
Operating Junction and Storage Temperature	T _j , T _{stg}	-55~+150	°C	

- Note : 1. Pulse width limited by maximum junction temperature.
 2. Pulse width ≤ 300μs, duty cycle ≤ 2%.
 3. Surface mounted on FR-4 board.
 3. Human body model, 1.5kΩ in series with 100pF

Electrical Characteristics (at T_A=25°C unless otherwise noted)

Symbol	Min.	Typ.	Max.	Unit	Test Conditions
Static					
BV _{DSS}	20	-	-	V	V _{GS} = 0, I _D = 250μA
ΔBV _{DSS} /ΔT _J	-	0.02	-	V/°C	Reference to 25°C, I _D = 1mA
V _{GS(th)}	0.5	0.92	1.2	V	V _{DS} = V _{GS} , I _D = 250μA
I _{GSS}	-	-	±10	μA	V _{GS} = ± 8V, V _{DS} = 0
I _{DSS}	-	-	1		V _{DS} = 20V, V _{GS} = 0
	-	-	10	V _{DS} = 16V, V _{GS} = 0 (T _J = 70°C)	
*R _{DS(ON)}	-	320	450	mΩ	V _{GS} = 4.5V, I _D = 600mA
	-	510	700		V _{GS} = 2.5V, I _D = 500mA
	-	980	1200		V _{GS} = 1.8V, I _D = 350mA
*G _{FS}	-	1	-	S	V _{DS} = 10V, I _D = 400mA
Dynamic					
C _{iss}	-	60	-	pF	V _{DS} = 10V, V _{GS} = 0, f = 1MHz
C _{oss}	-	14	-		
C _{rss}	-	9	-		
t _{d(ON)}	-	5	-	ns	V _{DS} = 10V, I _D = 200mA, V _{GS} = 4.5V R _G = 10Ω
t _r	-	5	-		
t _{d(OFF)}	-	24	-		
t _f	-	18	-		
Q _g	-	0.76	-	nC	V _{DS} = 10V, I _D = 250mA, V _{GS} = 4.5V
Q _{gs}	-	0.074	-		
Q _{gd}	-	0.27	-		
Source-Drain Diode					
*V _{SD}	-	0.8	1.2	V	V _{GS} = 0V, I _S = 150mA

*Pulse Test : Pulse Width ≤ 300μs, Duty Cycle ≤ 2%.

Thermal Performance

Parameter	Symbol	Limit	Unit
Thermal Resistance, Junction-to-Ambient(PCB mounted)	R _{th,ja}	833	°C/W

Typical Characteristics

Typical Output Characteristics

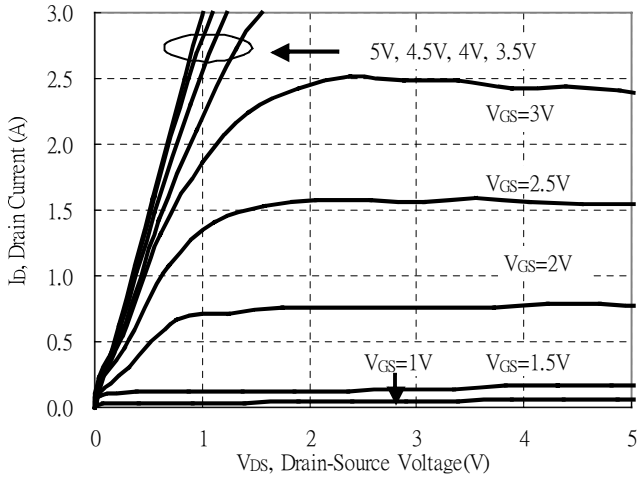

Brekdown Voltage vs Ambient Temperature

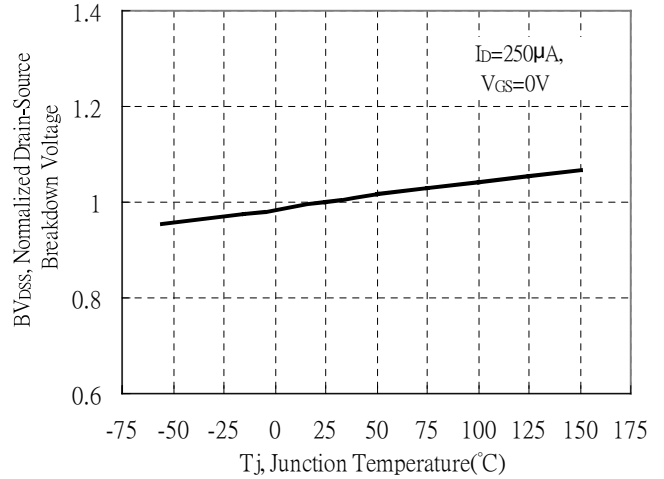

Static Drain-Source On-State resistance vs Drain Current

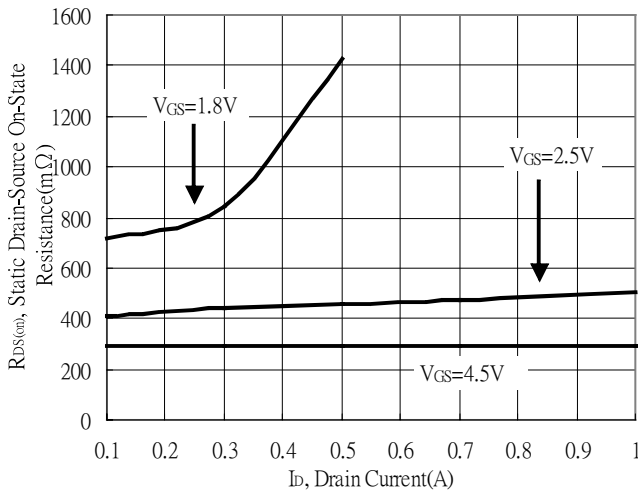

Reverse Drain Current vs Source-Drain Voltage

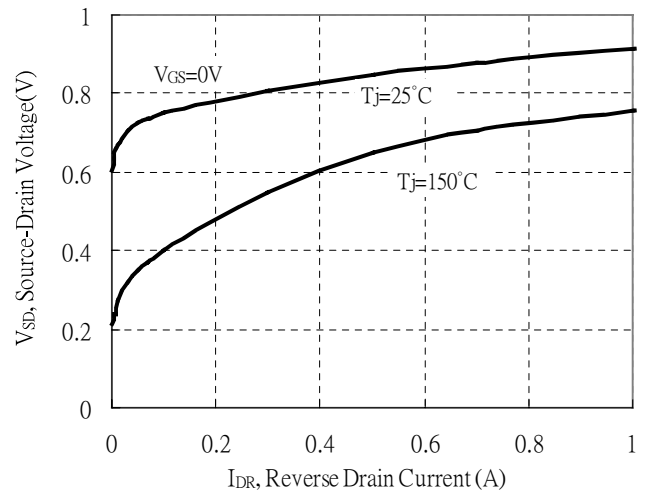

Static Drain-Source On-State Resistance vs Gate-Source Voltage

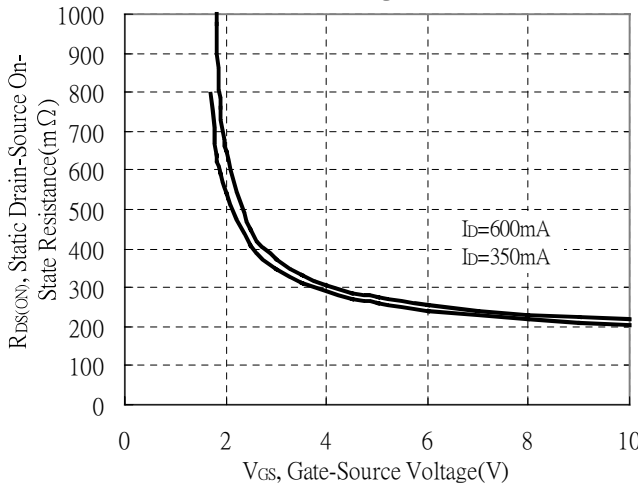

Drain-Source On-State Resistance vs Junction Temperature

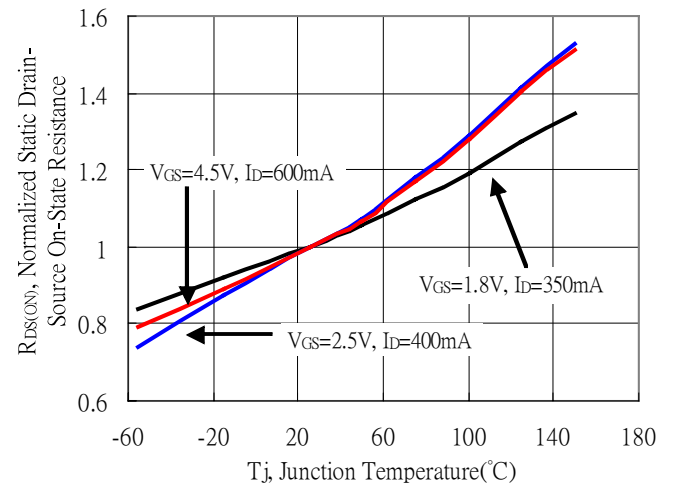

Company reserves the right to improve product design, functions and reliability without notice.

REV:A

Typical Characteristics(Cont.)

Capacitance vs Drain-to-Source Voltage

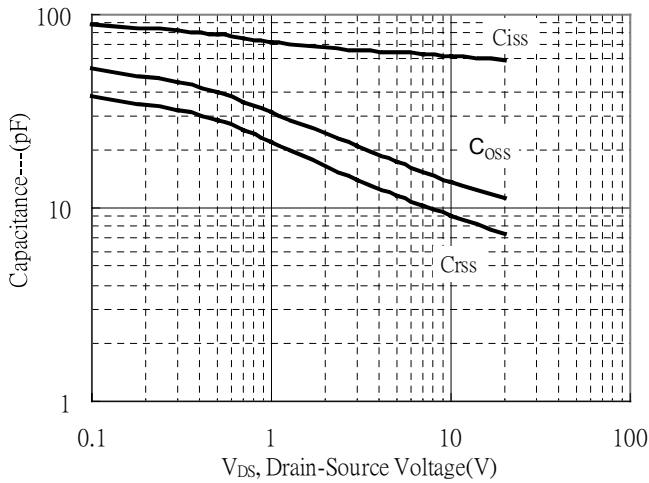

Threshold Voltage vs Junction Temperature

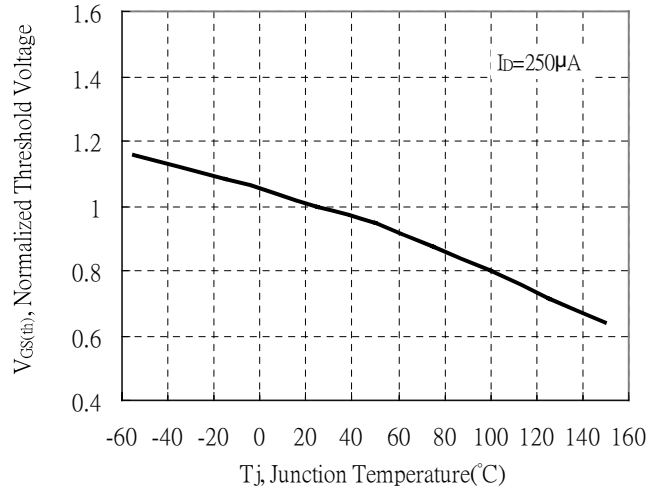

Single Pulse Power Rating, Junction to Ambient
(Note on page 2)

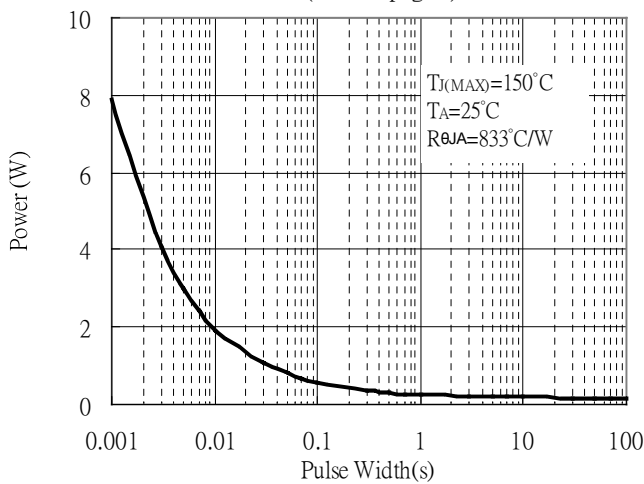

Gate Charge Characteristics

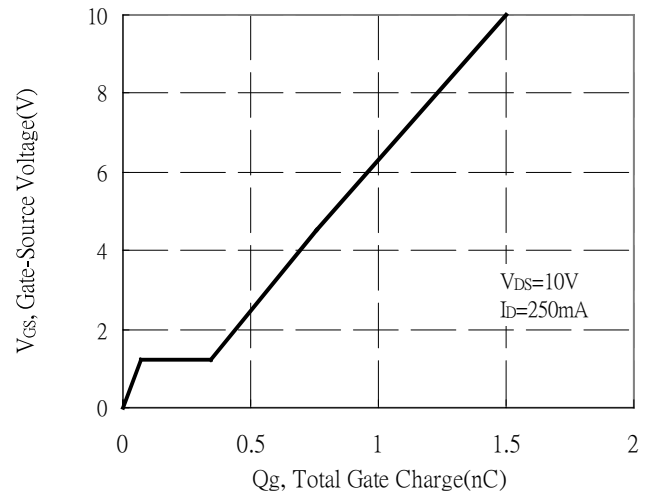

Maximum Safe Operating Area

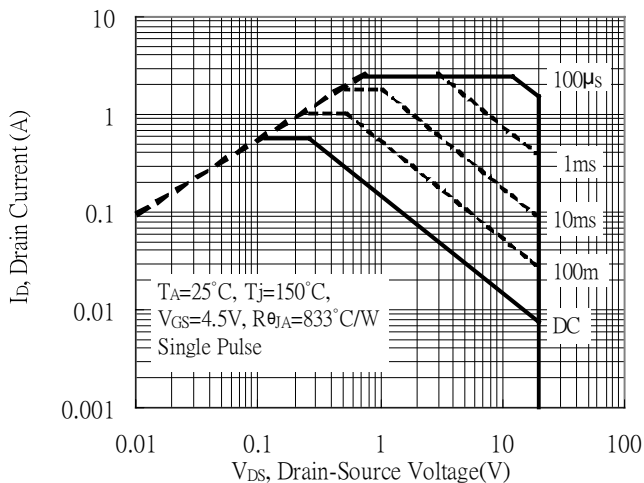

Maximum Drain Current vs Junction Temperature

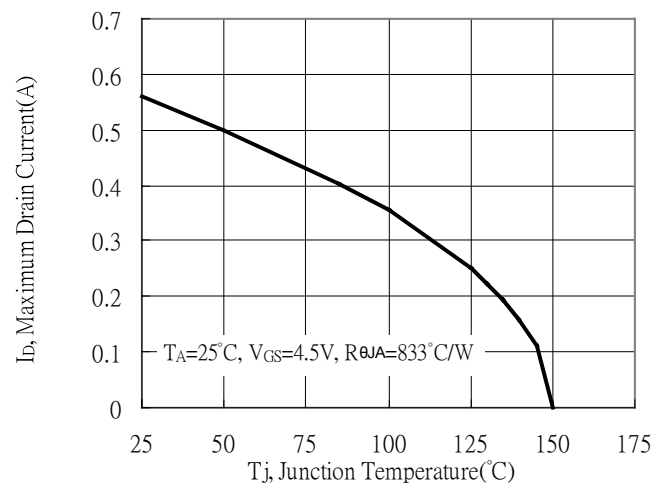

Company reserves the right to improve product design, functions and reliability without notice.

Typical Characteristics(Cont.)

Typical Transfer Characteristics

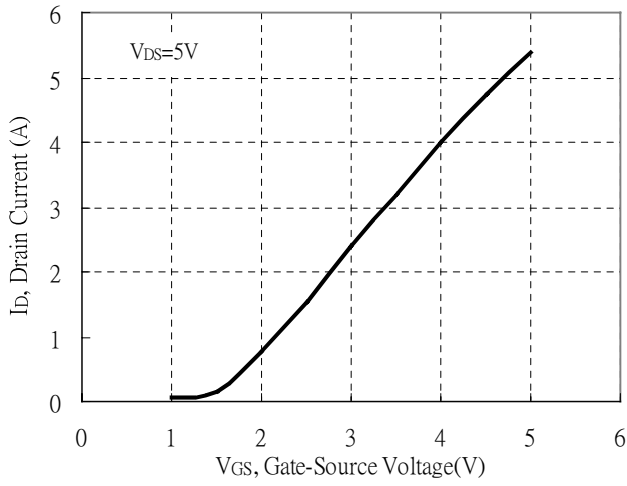

Power Derating Curve

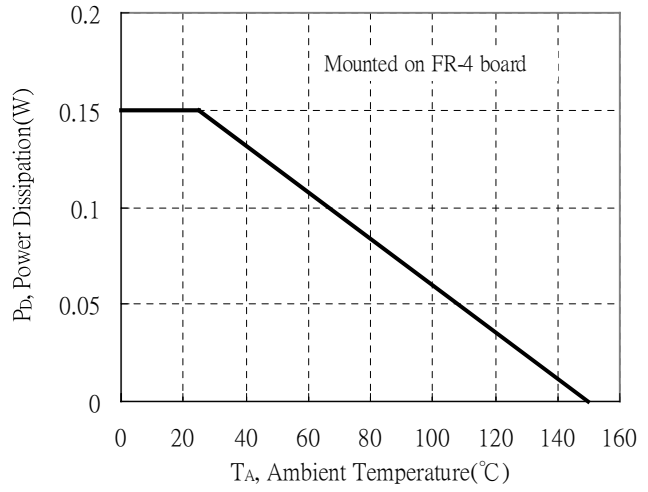

Forward Transfer Admittance vs Drain Current

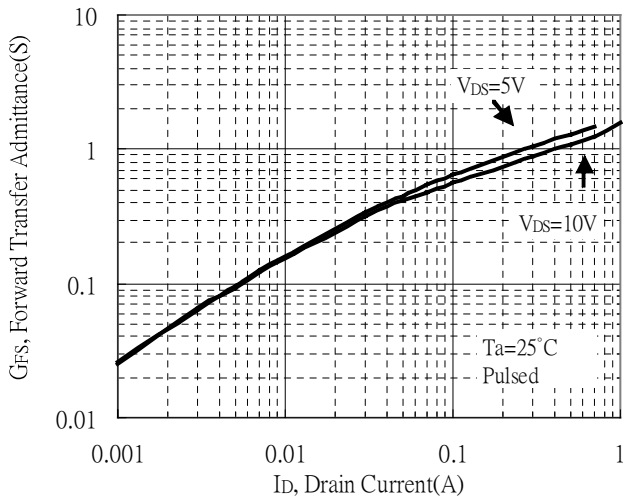

Transient Thermal Response Curves

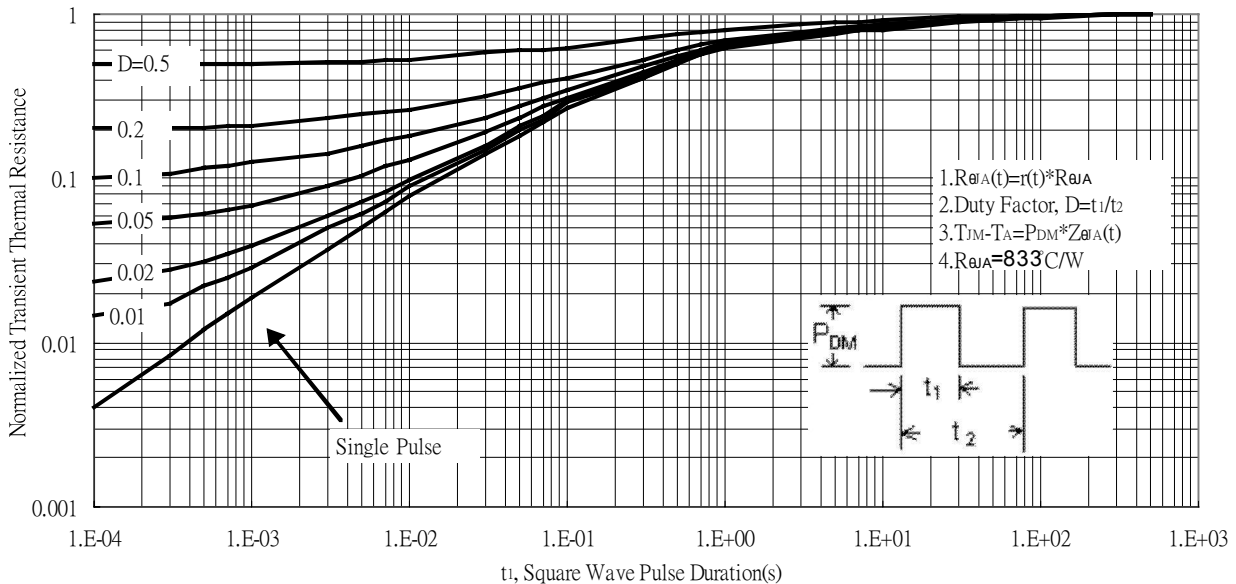

Company reserves the right to improve product design, functions and reliability without notice.

Reel Taping Specification

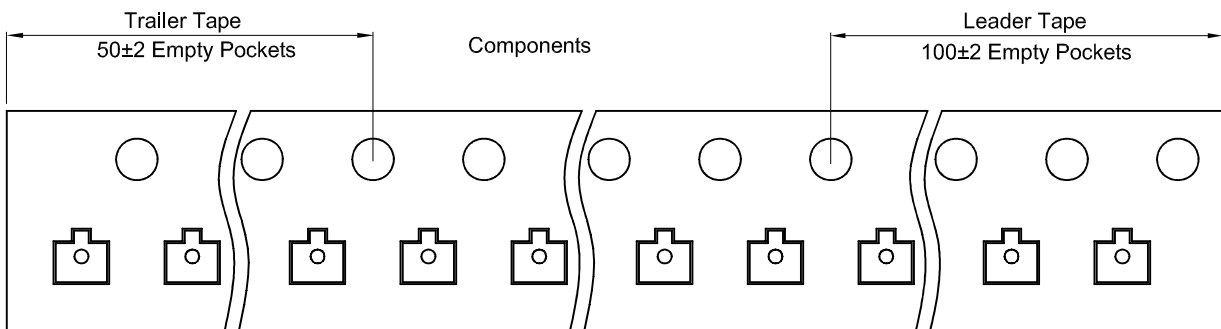
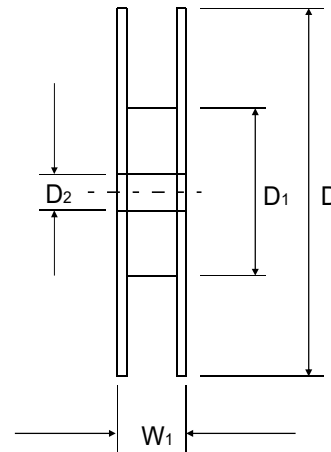
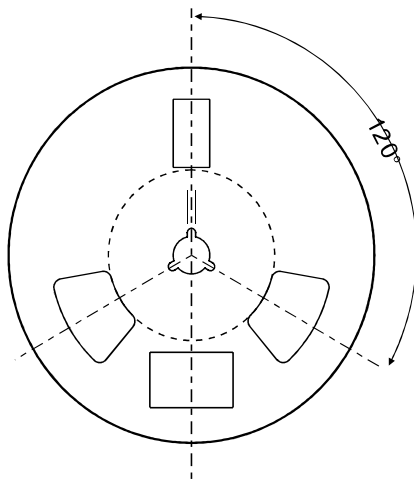
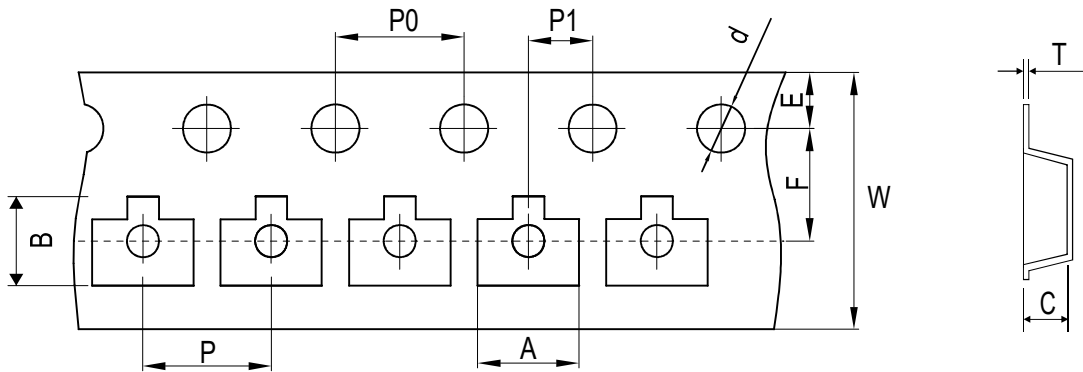

SOT-523	SYMBOL	A	B	C	d	D	D1	D2
	(mm)	1.85 ± 0.05	1.85 ± 0.05	0.875 ± 0.05	1.50 ± 0.10	178 ± 2.00	54.40 ± 1.00	13.00 ± 1.00
	(inch)	0.073 ± 0.002	0.073 ± 0.002	0.034 ± 0.002	0.059 ± 0.004	7.008 ± 0.079	2.142 ± 0.039	0.512 ± 0.039

SOT-523	SYMBOL	E	F	P	P0	P1	W	W1
	(mm)	1.75 ± 0.10	3.50 ± 0.10	4.00 ± 0.10	4.00 ± 0.10	2.00 ± 0.10	8.00 + 0.30 / - 0.10	12.30 ± 1.00
	(inch)	0.069 ± 0.004	0.138 ± 0.004	0.157 ± 0.004	0.157 ± 0.004	0.079 ± 0.004	0.315 + 0.012 / - 0.004	0.484 ± 0.039

Company reserves the right to improve product design, functions and reliability without notice.

Marking Code

Part Number	Marking Code
CMSN1012H3-HF	QT

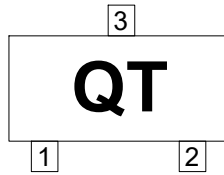

Suggested PAD Layout

SIZE	SOT-523	
	(mm)	(inch)
A	0.60	0.024
B	0.50	0.020
C	0.40	0.016
D	1.00	0.039
E	1.24	0.049
F	1.84	0.072

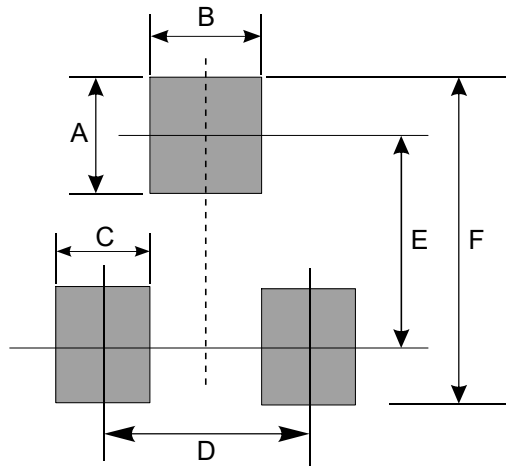

Standard Packaging

Case Type	REEL PACK	
	REEL (pcs)	Reel Size (inch)
SOT-523	3,000	7